

BASE		
APPLICATION: VERTICAL	NOTES: STANDARD TRIM	
SCALE: NTS	REVISION:	DATE:
DRAWN: DG	DATE: 12-10-11	
CHECK:	DATE:	
21200 FM362, WALLER, TEXAS 77484	281-807-7400	WWW.GSPLC.COM

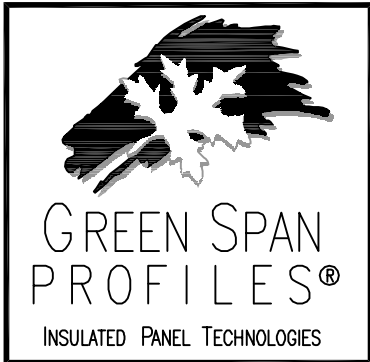

DOOR HEADER		
APPLICATION: VERTICAL	NOTES: STANDARD TRIM	
SCALE: NTS	REVISION:	DATE:
DRAWN: DG	DATE: 12-10-11	
CHECK:	DATE:	
21200 FM362, WALLER, TEXAS 77484	281-807-7400	WWW.GSPLC.COM

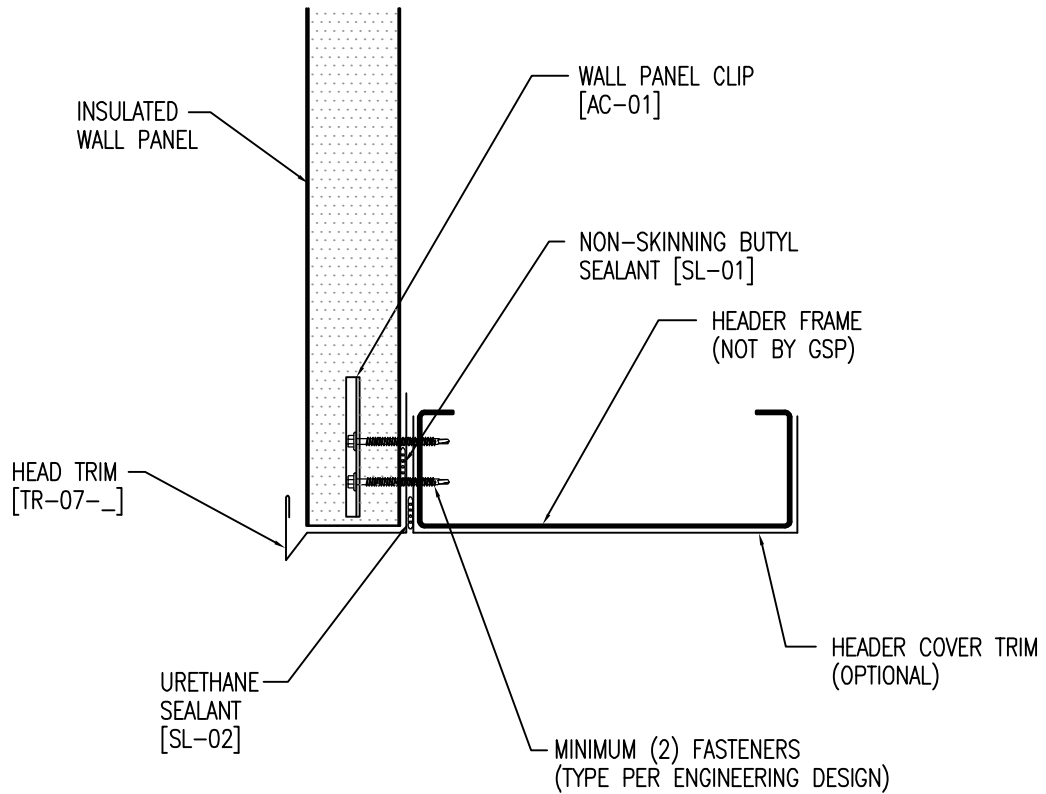
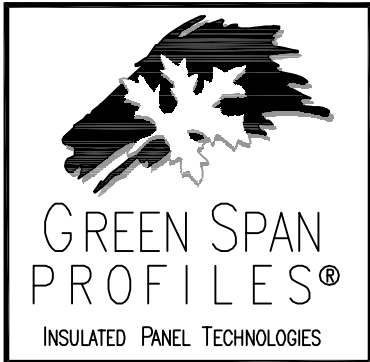
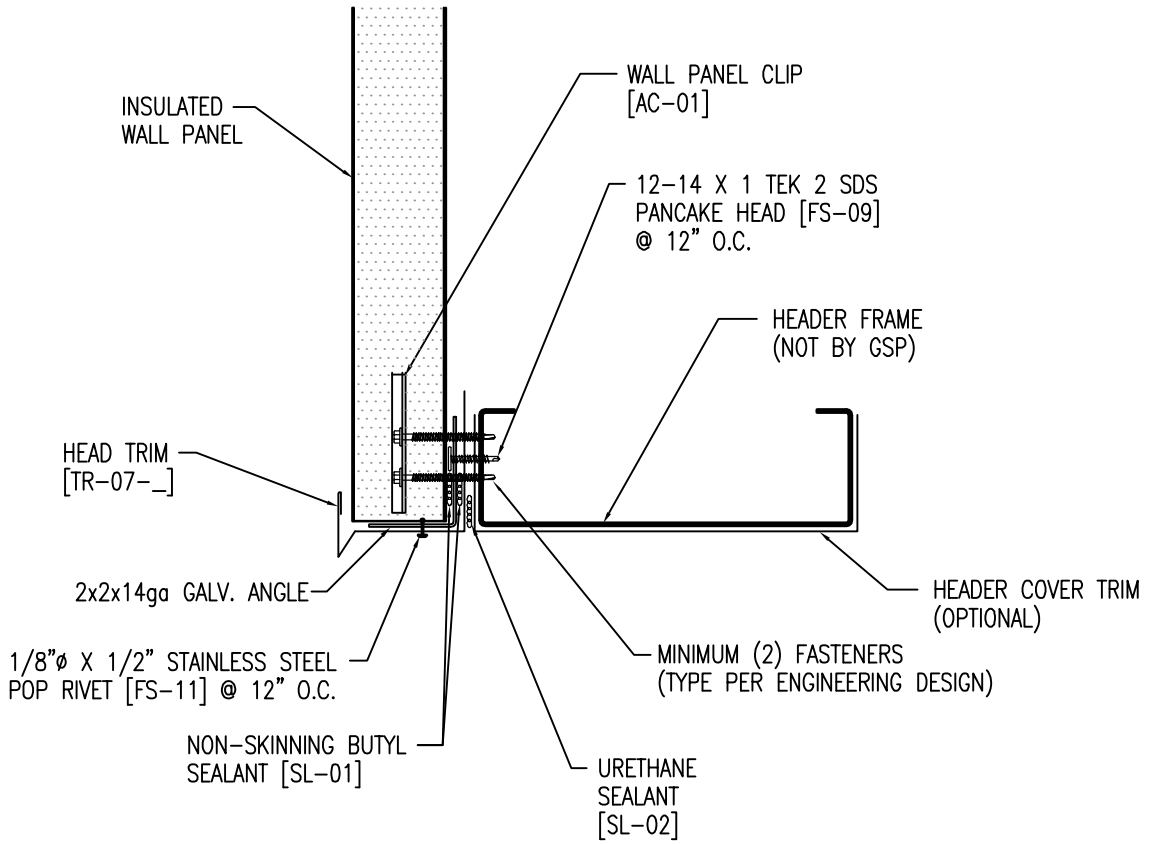

DOOR HEADER W/SUPPORT		
APPLICATION: VERTICAL	NOTES: STANDARD TRIM	
SCALE: NTS	REVISION:	DATE:
DRAWN: DG	DATE: 12-10-11	
CHECK:	DATE:	
21200 FM362, WALLER, TEXAS 77484	281-807-7400	WWW.GSPLC.COM

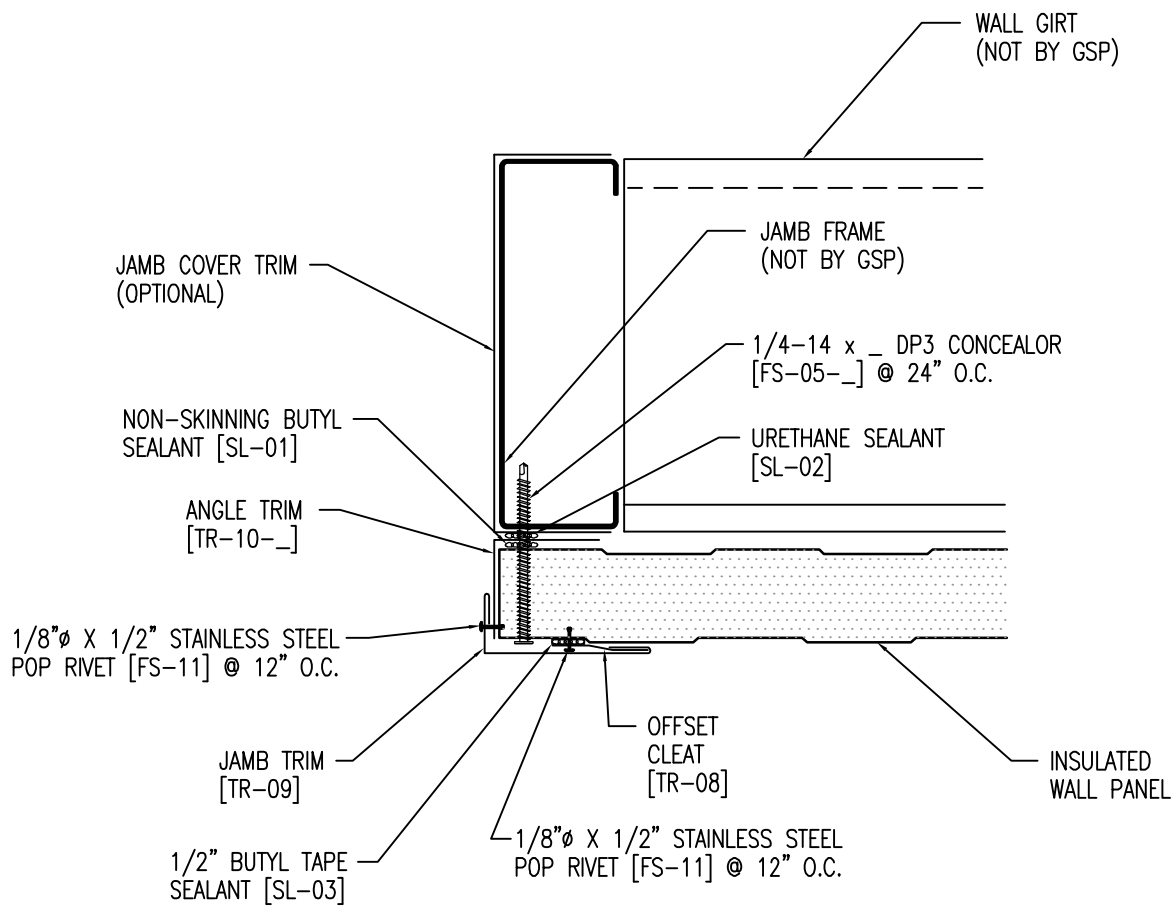

DOOR JAMB		
APPLICATION: VERTICAL	NOTES: STANDARD TRIM	
SCALE: NTS	REVISION:	DATE:
DRAWN: DG	DATE: 12-10-11	
CHECK:	DATE:	
21200 FM362, WALLER, TEXAS 77484	281-807-7400	WWW.GSPLC.COM

NOTE: FIELD CUT STARTING PANEL AND ENDING PANEL AS REQUIRED AT CORNER TRANSITION.

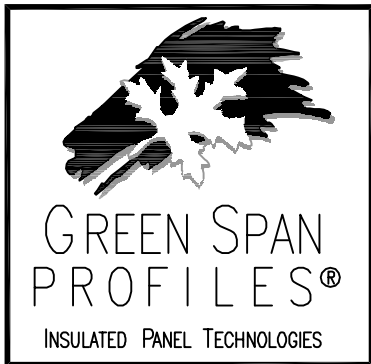
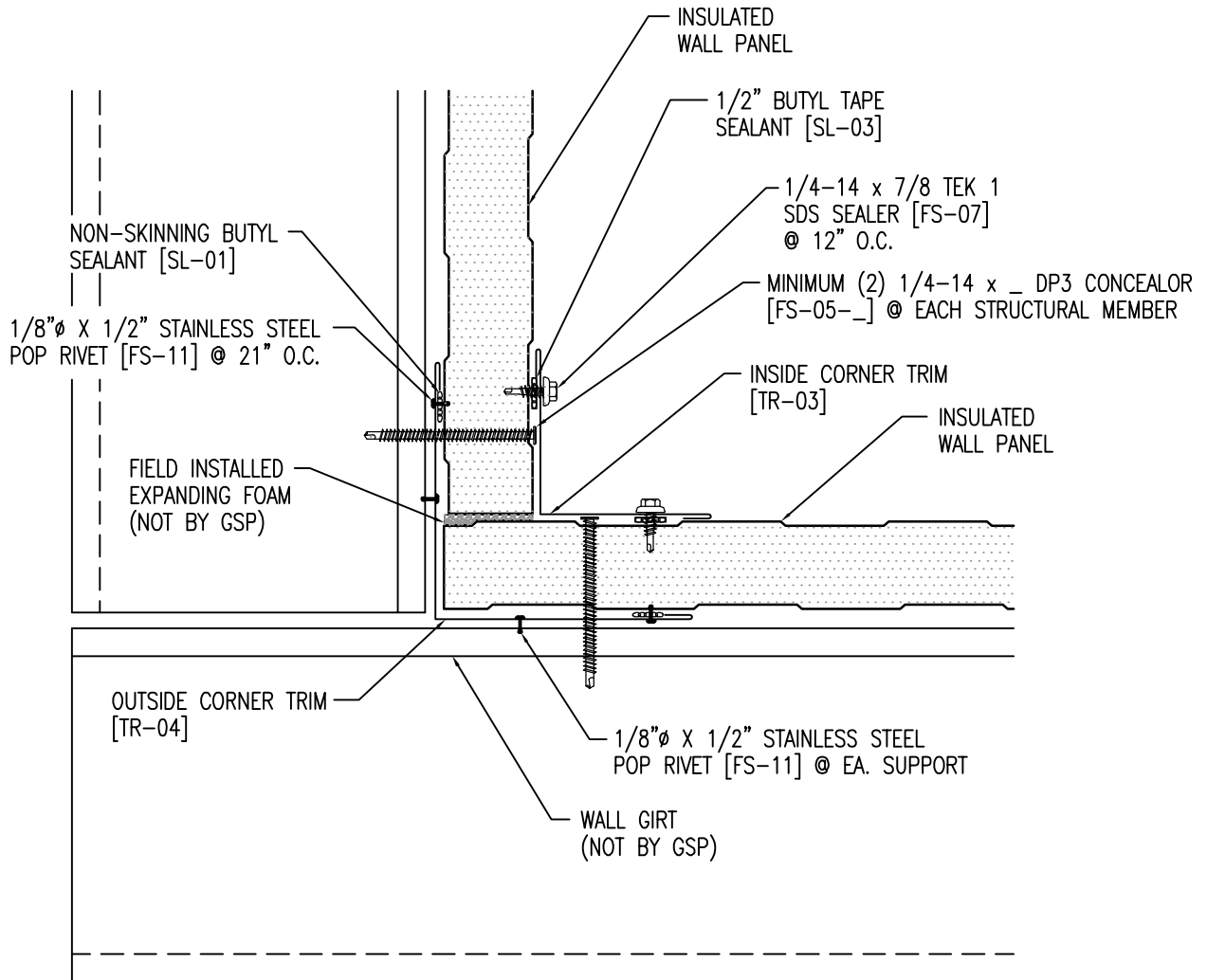

INSIDE CORNER		
APPLICATION: VERTICAL	NOTES: STANDARD TRIM	
SCALE: NTS	REVISION:	DATE:
DRAWN: DG	DATE: 12-10-11	
CHECK:	DATE:	
21200 FM362, WALLER, TEXAS 77484	281-807-7400	WWW.GSPLC.COM

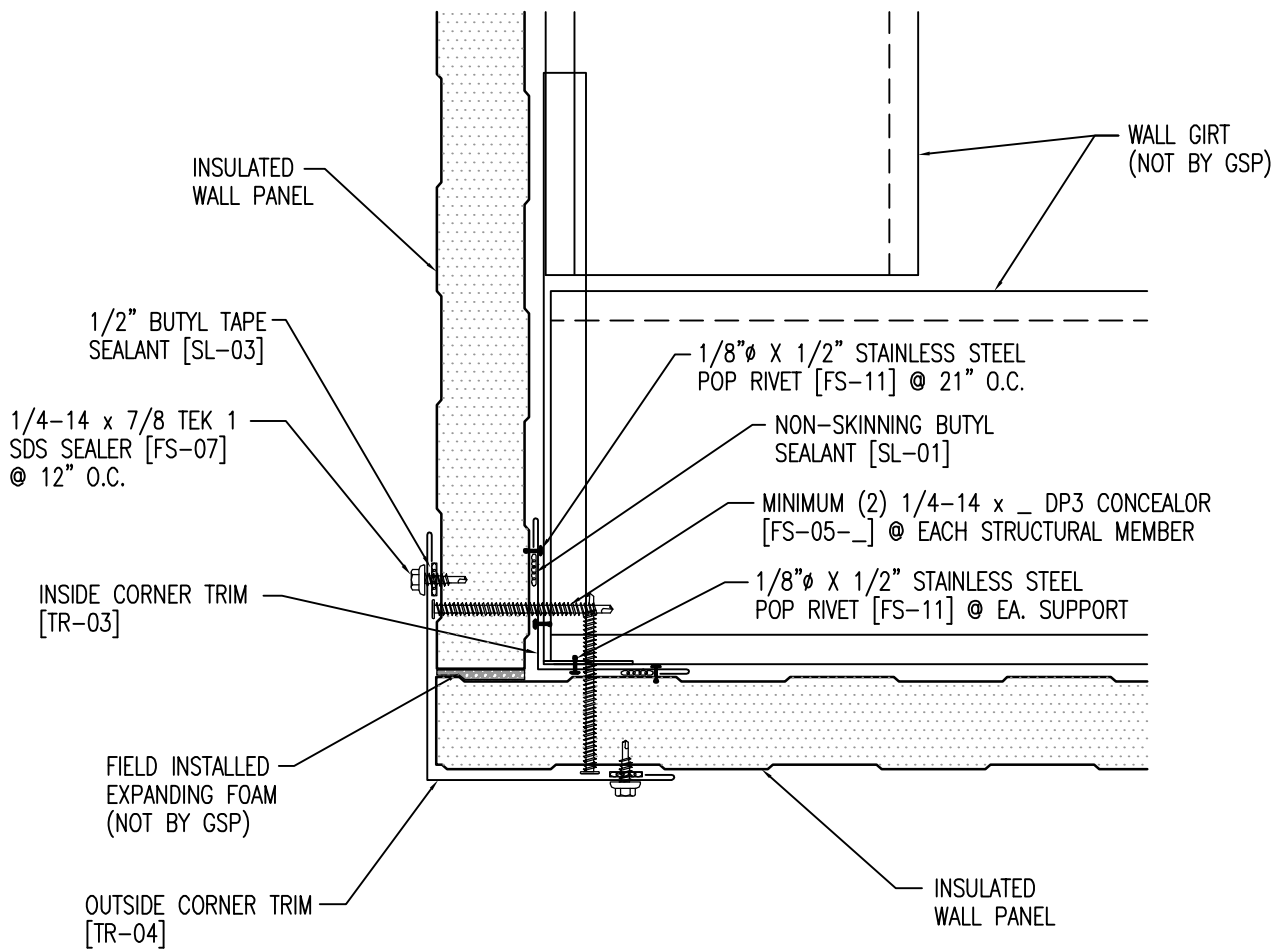

NOTE: FIELD CUT STARTING PANEL AND ENDING PANEL AS REQUIRED AT CORNER TRANSITION.

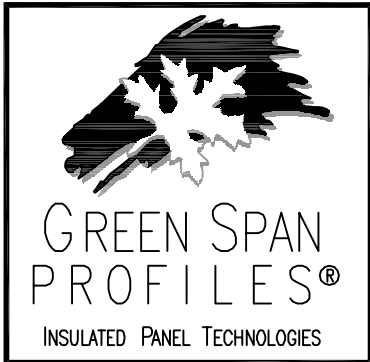

OUTSIDE CORNER		
APPLICATION: VERTICAL	NOTES: STANDARD TRIM	
SCALE: NTS	REVISION:	DATE:
DRAWN: DG	DATE: 12-10-11	
CHECK:	DATE:	
21200 FM362, WALLER, TEXAS 77484	281-807-7400	WWW.GSPLC.COM

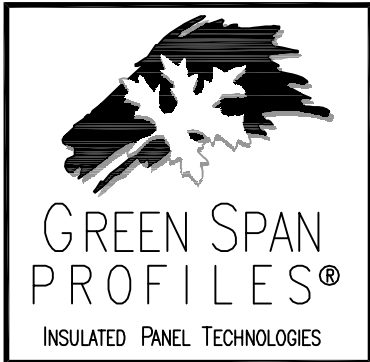
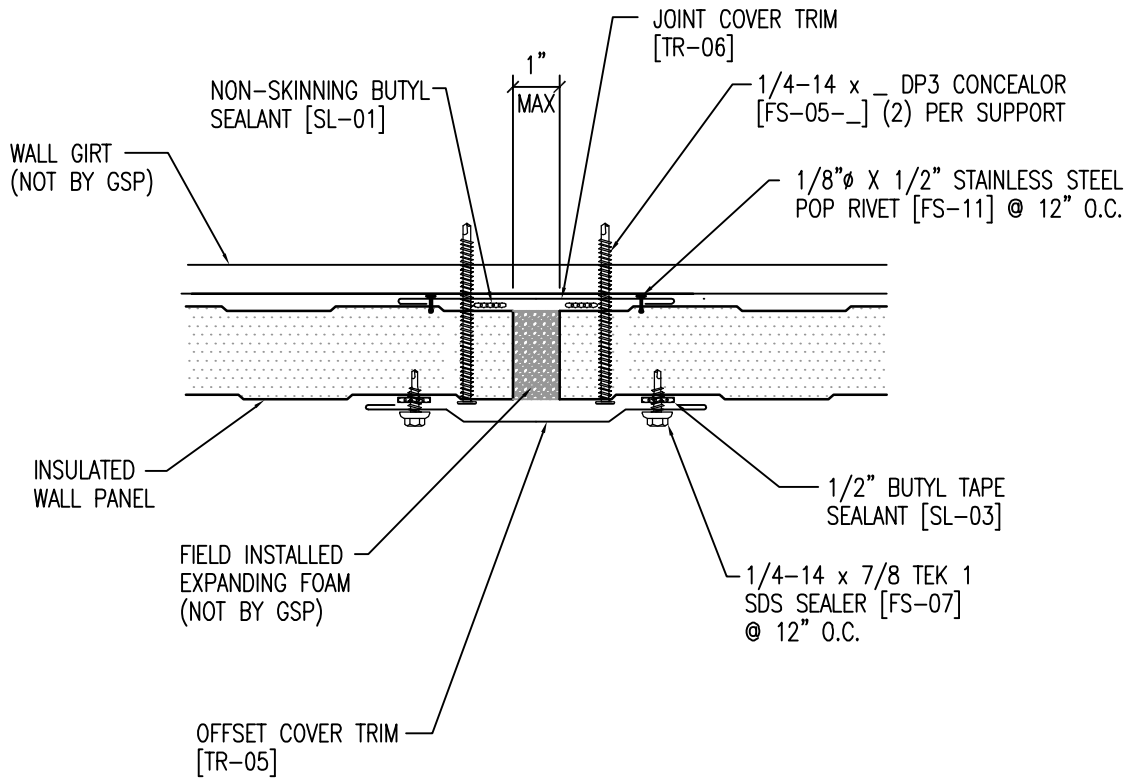

PANEL SIDE JOINT		
APPLICATION: VERTICAL	NOTES: STANDARD TRIM	
SCALE: NTS	REVISION:	DATE:
DRAWN: DG	DATE: 12-10-11	
CHECK:	DATE:	
21200 FM362, WALLER, TEXAS 77484	281-807-7400	WWW.GSPLC.COM

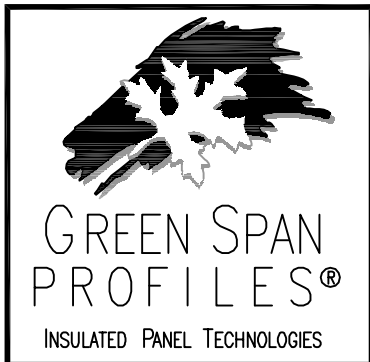
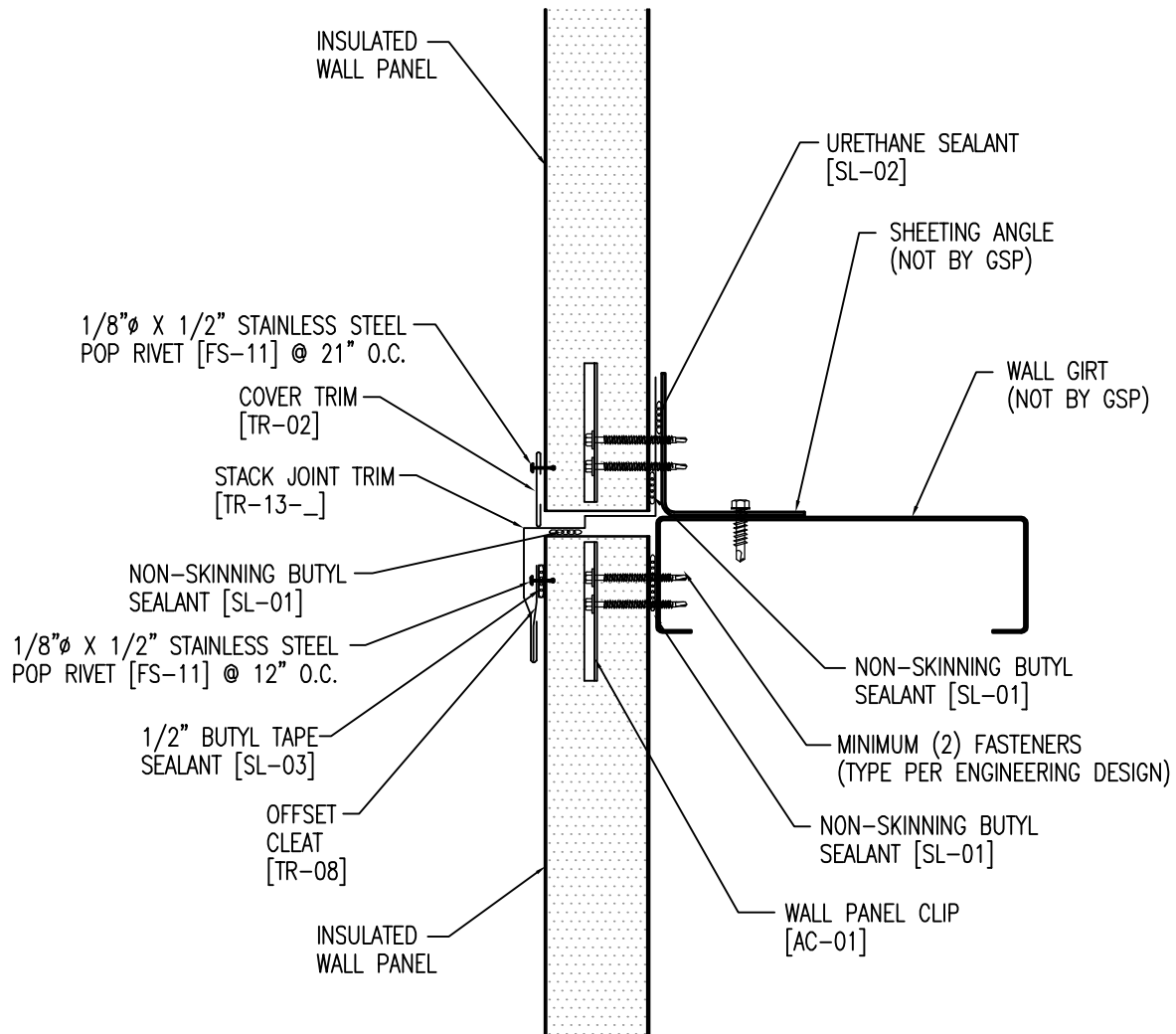

## STACK JOINT

APPLICATION: VERTICAL

NOTES: STANDARD TRIM

SCALE: NTS

REVISION:

DATE:

DRAWN: DG

DATE: 12-10-11

CHECK:

DATE:

21200 FM362, WALLER, TEXAS 77484

281-807-7400

WWW.GSPCLC.COM



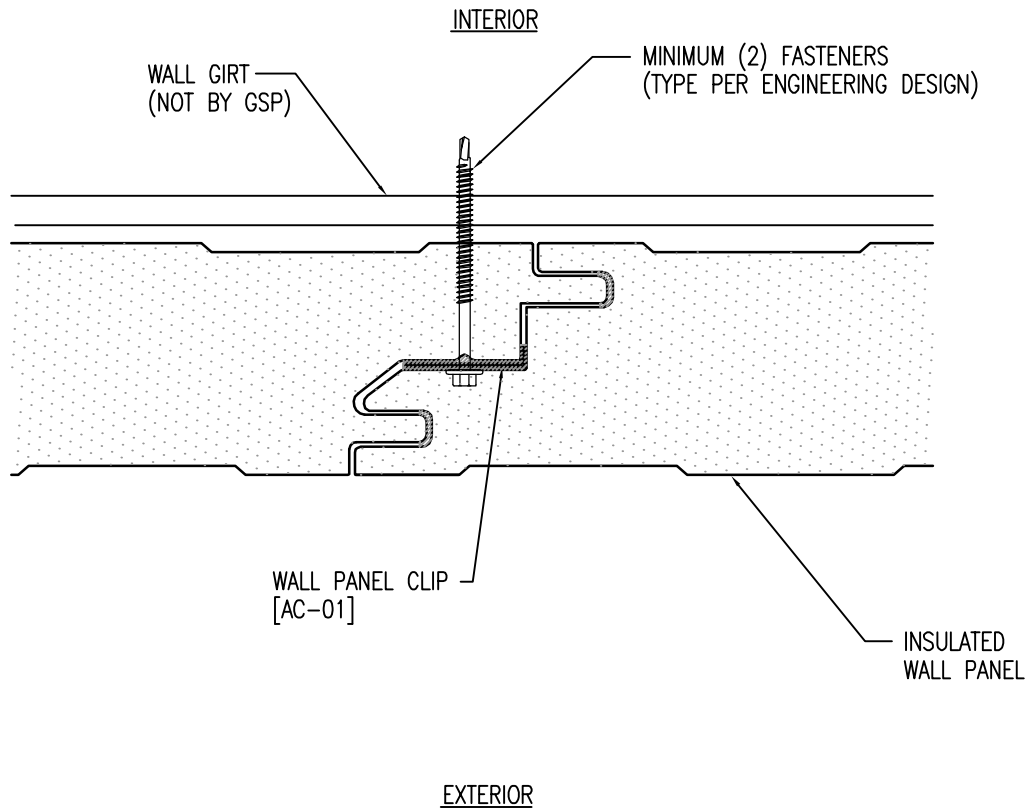

3/8" UNIFORM BEAD OF NON-SKINNING BUTYL SEALANT MUST BE APPLIED IN EITHER OR BOTH FEMALE GROOVES DEPENDING ON VAPOR SEAL REQUIREMENTS

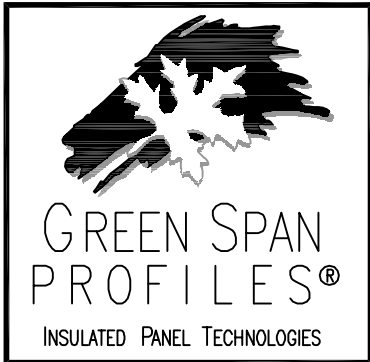

WALL PANEL SIDELAP		
APPLICATION: VERTICAL	NOTES: STANDARD TRIM	
SCALE: NTS	REVISION:	DATE:
DRAWN: DG	DATE: 12-10-11	
CHECK:	DATE:	
21200 FM362, WALLER, TEXAS 77484	281-807-7400	WWW.GSPLC.COM

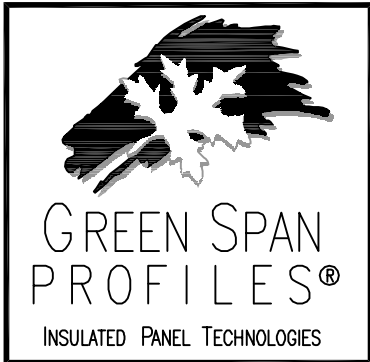
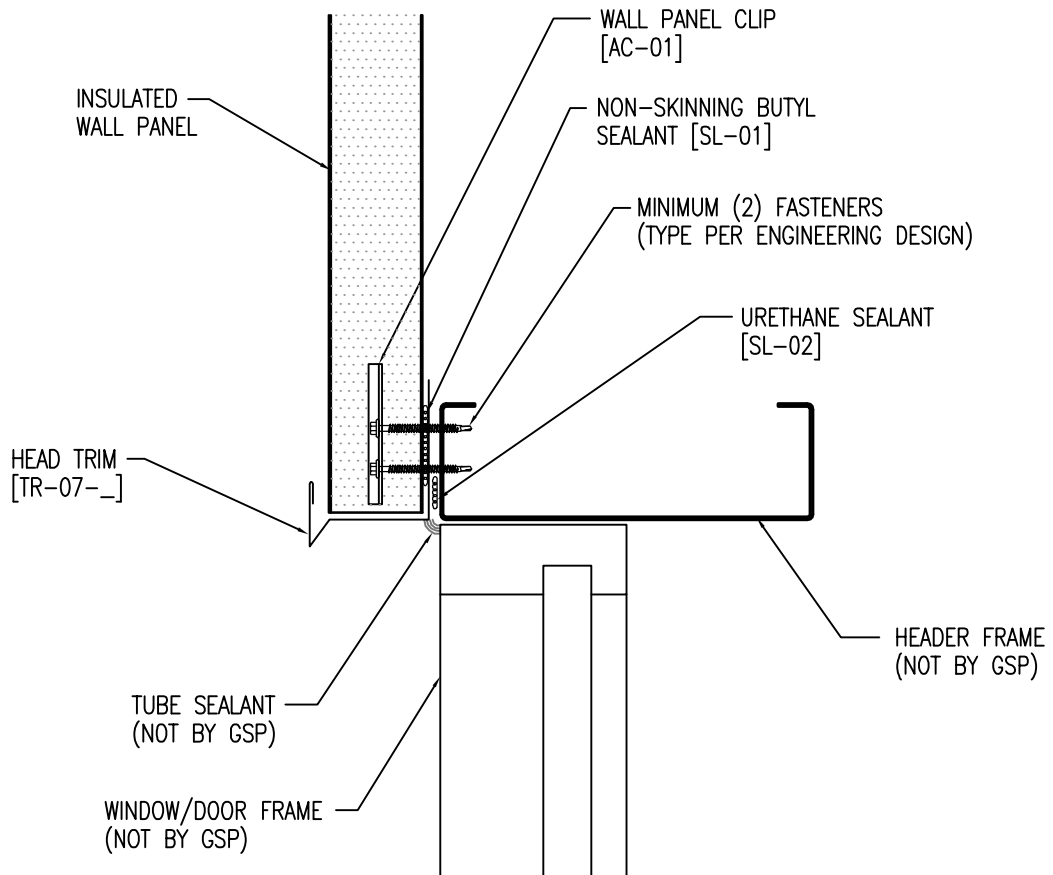

WINDOW HEADER		
APPLICATION: VERTICAL	NOTES: STANDARD TRIM	
SCALE: NTS	REVISION:	DATE:
DRAWN: DG	DATE: 12-10-11	
CHECK:	DATE:	
21200 FM362, WALLER, TEXAS 77484	281-807-7400	WWW.GSPLC.COM

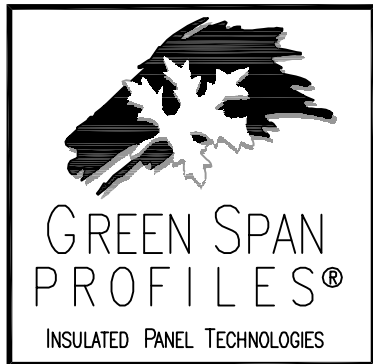
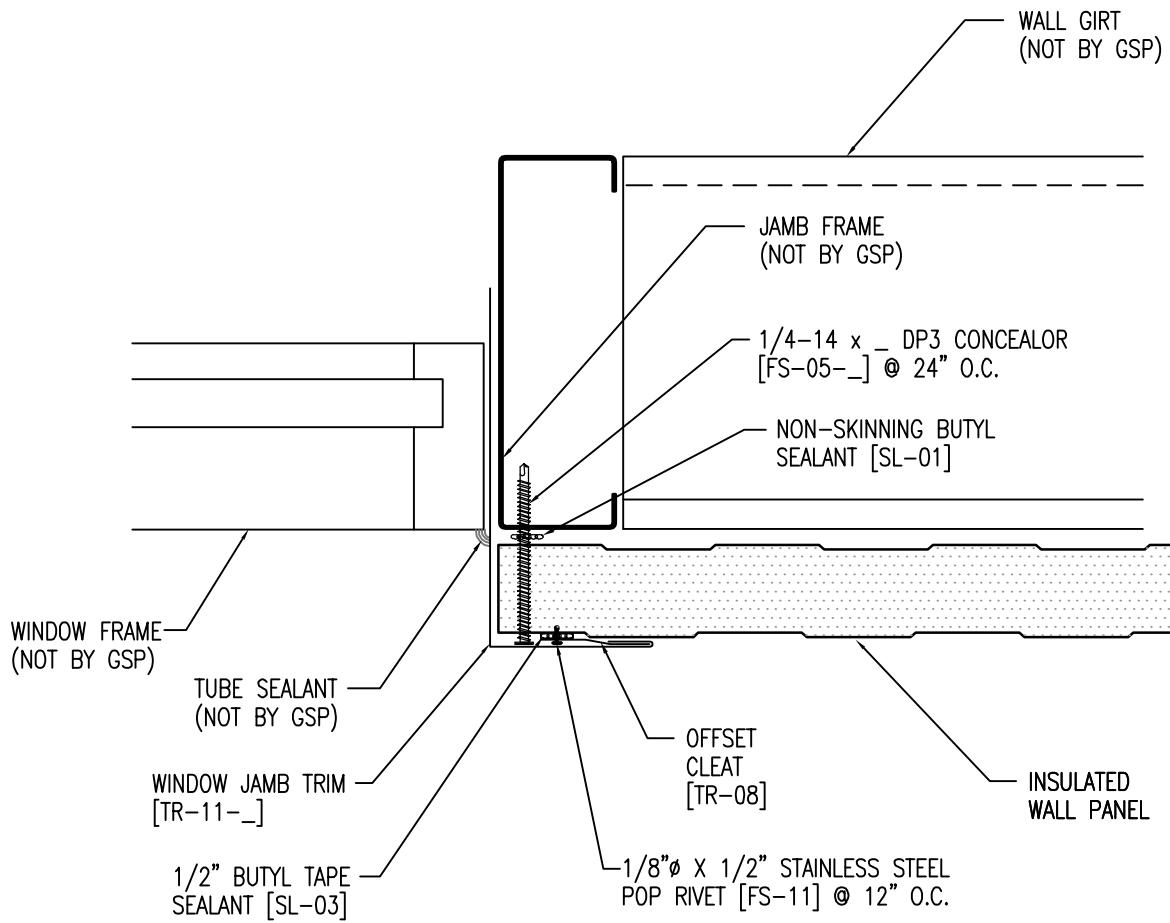

WINDOW JAMB		
APPLICATION: VERTICAL	NOTES: STANDARD TRIM	
SCALE: NTS	REVISION:	DATE:
DRAWN: DG	DATE: 12-10-11	
CHECK:	DATE:	
21200 FM362, WALLER, TEXAS 77484	281-807-7400	WWW.GSPLC.COM

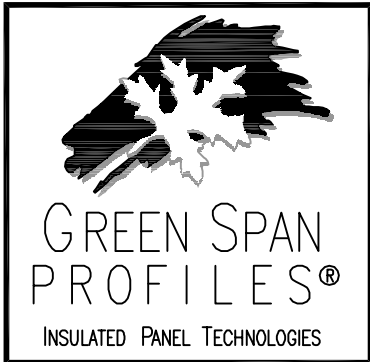
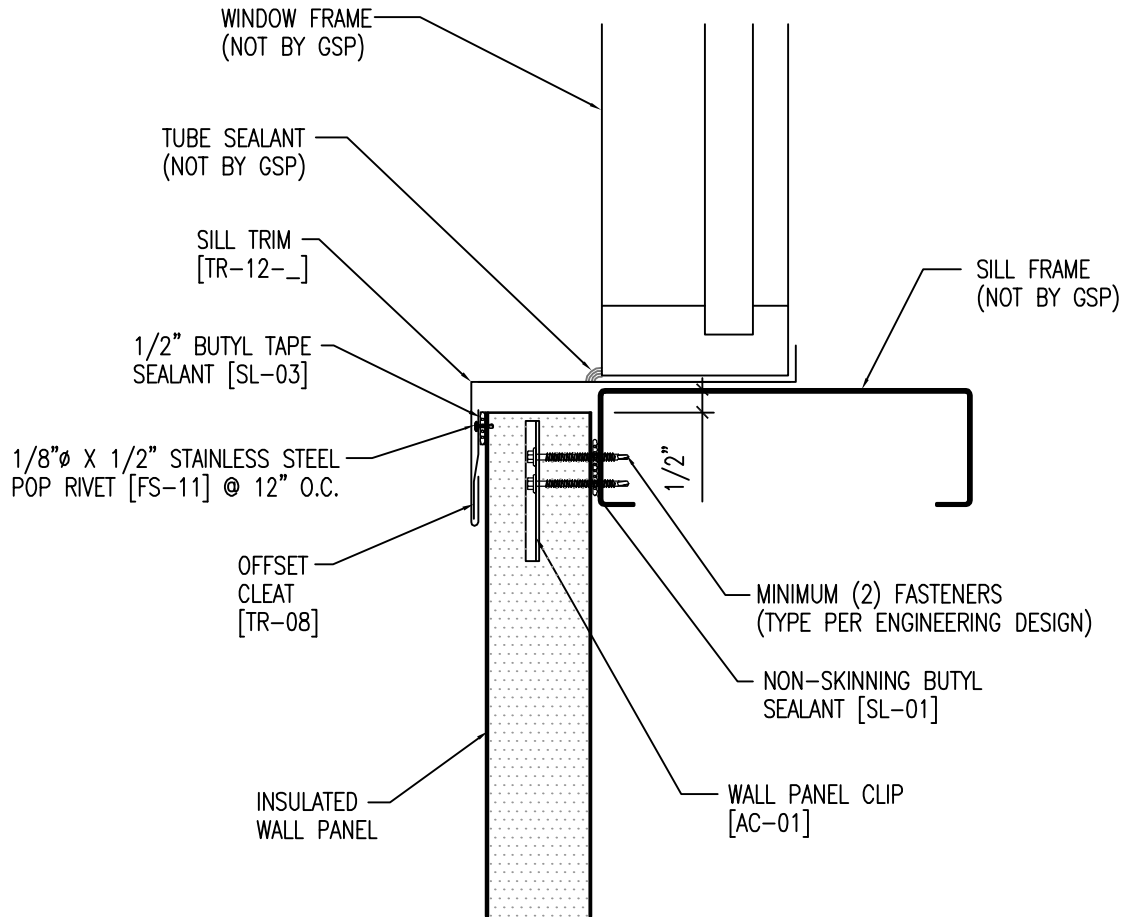

WINDOW SILL		
APPLICATION: VERTICAL	NOTES: STANDARD TRIM	
SCALE: NTS	REVISION:	DATE:
DRAWN: DG	DATE: 12-10-11	
CHECK:	DATE:	
21200 FM362, WALLER, TEXAS 77484	281-807-7400	WWW.GSPLC.COM