



TECHNICAL BULLETIN

Issue Date: September 9, 2002

No. 03-145-02

UL Construction #343

Medallion Lok

UL580 Class 90 Wind Uplift

- Metal Roof Deck Panels*** - No. 24 MSG min coated steel. Panel width 18 in. max., 10 in. min. Rib height 1-3/4 in. at female side. Panels continuous over three or more clips with no endlaps. A bead of sealant may be used at panel side joints.
McElroy Metal Mill, Inc. "Medallion-Lok"
- Roof Deck Fasteners*(Panel Clips)** – One piece assembly, 3-1/2 in. wide, 1-7/8 in. high. Min thickness No. 18 MSG. Clips spaced 36 in. OC, max, fastened to plywood deck.
McElroy Metal Mill, Inc. "Medallion-Lok Clip"
- Fasteners (Screws)** – Fasteners used to attach panel clips (Item 2) to plywood to be No. 10-12 by 1 in. long pancake head, No. 2 Phillips drive, A-point, coated steel screw. Min two fasteners per clip to be used.
- Underlayment** – Underlayment used over plywood deck to be Type 15 or 30 organic felt. Sides overlapped min 2 in., end laps per manufacturer's instructions. Felt nailed to plywood deck with 1-1/4 in. long steel cap nails, located per manufacturer's instructions. Nail spacing to be max 12 in. OC at the side lap and max 24 in. OC in interior rows.
As an Alternate – A self-adhering modified bitumen water proofing membrane may be used, installed per manufacturer's instructions. Note – when alternate is used the plywood joints need not be sealed.
- Plywood Decking** – Plywood decking to be graded per PS83 specifications, 19/32 in. thick, exposure 1, APA Rated Sheathing (42/20) square edged. Butt ends not blocked. All butt and side joints to be sealed with a one-part urethane caulk sealant applied with a caulking gun and feathered outward from the joint. (Note exception under Item No. 4, Alternate.)
- Supports - (Not Shown)** – Spaced max of 24 in. OC. Any of the following types may be used to support the plywood decking:
 - Nom 2 by 6 in., No. 2 grade or better S-P-F, Hemlock Fir, Douglass Fir or Southern Yellow Pine or equivalent.
 - Wood trusses with a nom 2 by 4 in. upper chord of the same grade as item a.
 - No. 22 MSG min cold formed coated steel (min yield to be 33,000 psi).
- Plywood Fasteners** – (Not Shown) – Fasteners used to attach the plywood deck to the supports to be as follows:
 - For plywood-to-wood supports No. 8-18 by 1-7/8 in. long bugle-head steel screws with a No. 2 Phillips drive, a "Hi-Low" thread pattern and an "S-Point".
 - As an alternate to Item a, 8d common nails may be used.
 - For plywood-to-steel supports for a steel thickness less than No. 20 MSG No. 7-19 by 1-1/4 in. long bugle-head steel screws with a No. 2 Phillips drive "Hi-Low" threads and an "S-Point". For a steel thickness greater than No. 20 MSG to No. 16 MSG, No. 6-20 by 1-1/4 in. long bugle-head steel screws with a No. 2 Phillips drive and a S12 (TEKS/3) supR point.
Spacing: Fastener spacing for all fastener types to be 6 in. OC at the plywood edges and 12 in. OC in the interior. The following items may be used in conjunction with the "AEP SPAN" Metal Roof Deck Panels (Item 1). When used, the panel system is identified as "SNAP-SEAM (SBS)".

Refer to General Information, Roof Deck Construction, (Building Materials Directory) for items not evaluated.

*Bearing the UL Classification Mark

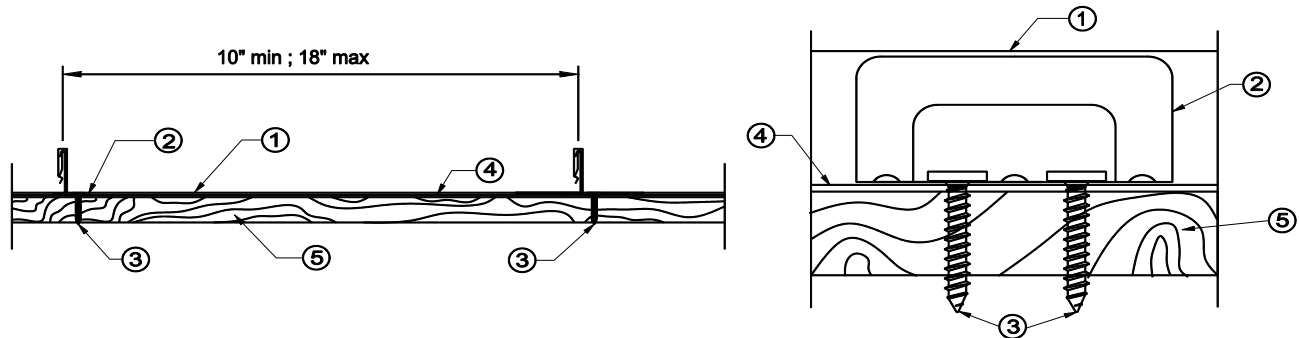

CORPORATE OFFICE
SHREVEPORT, LOUISIANA