

Trap-Tee Panel

Product Data

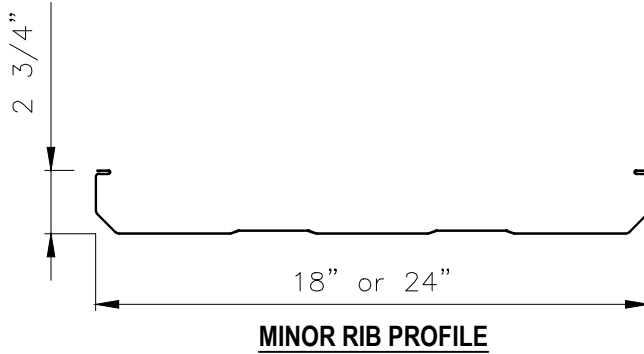

Applications

Mechanically Seamed roof panel used on slopes down to 1/4:12.

Substrates

Solid Wood Decking, Metal Deck, Rigid Insulation/Metal Deck or Open Framing. Best suited for simple sloped roofs without dormers, hips, valleys or other special conditions.

Material

Standard – 24 GA. ASTM A792 (50 ksi steel) AZ55 – Bare, AZ50 – Painted
 Optional – 22 GA. ASTM A792 (50 ksi steel) AZ55 – Bare, AZ50 – Painted
 – 20 GA. ASTM A792 (50 ksi steel) AZ55 – Bare, AZ50 – Painted

Manufacturing

Site formed – 18" and 24" Panel.

Factory formed – 18" Panel Only (Houston Plant Only) – Max. Length 40'-0"

Finishes

Acrylic Coated Galvalume®

Fluoropolymer (Kynar 500® PVDF resin-based)

Pan Conditions

Minor Ribs

Oil canning is inherent in all metal panels and is not cause for panel rejection.

Testing *

Uplift: ASTM E1592 (Pending)

Static Waterhead: ASTM 2140 (Pending)

Air & Water Infiltration: ASTM 1680, ASTM 1646 (Pending)

Testing and Approvals are product specific. Please inquire for details



MECHANICAL SEAMER

Order through Developmental Industries
 at www.mcelroyseamers.com
 (888)343-0456

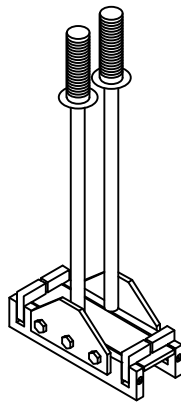

HAND SEAMER

Order through Developmental Industries
 at www.mcelroyseamers.com
 (888)343-0456

NOTE:

All data represented on this sheet may not be applicable to all widths and gauges. Please contact McElroy Metal for more information.

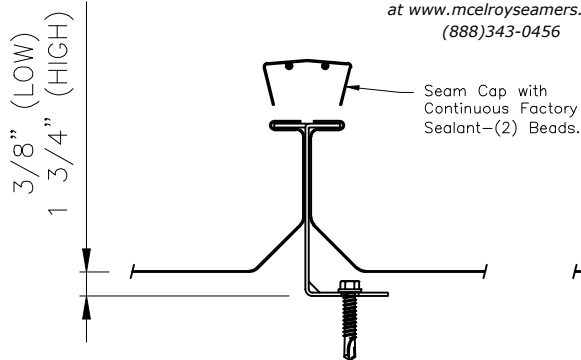

SEAM ENGAGEMENT

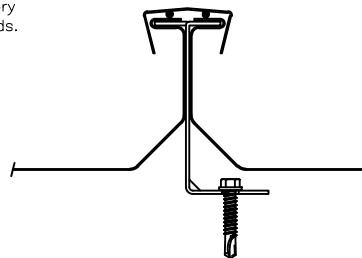

BEFORE SEAMING

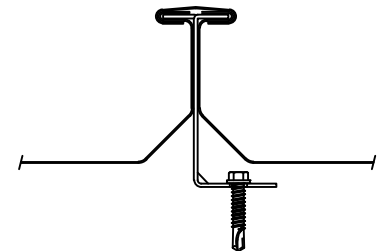

AFTER SEAMING



FOAM INSIDE CLOSURE

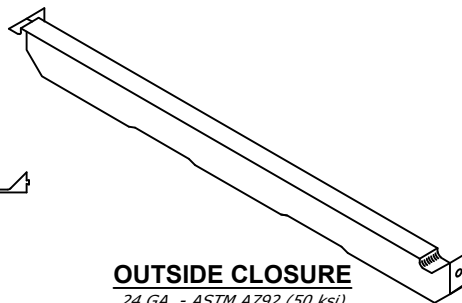

OUTSIDE CLOSURE
 24 GA. - ASTM A792 (50 ksi)

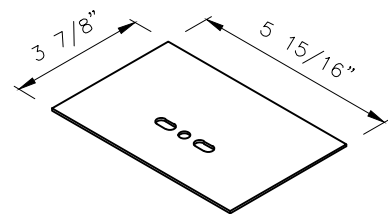

BEARING PLATE

16 GA.
 RED PRIMED - ASTM A1011 (55 ksi)
 GALVANIZED - ASTM A653 (55 ksi)

Trap-Tee Panel (Continued)

Product Data

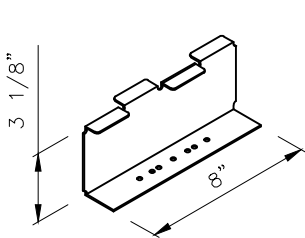

STANDARD CLIP

3/8" Offset
16 GA.

Standard: Galvanized G90 - ASTM A653 (50 ksi)

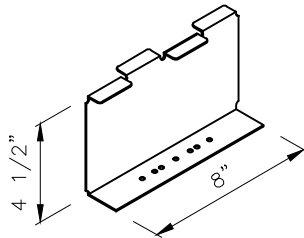

TALL CLIP

1 3/4" Offset
16 GA.

Standard: Galvanized G90 - ASTM A653 (50 ksi)

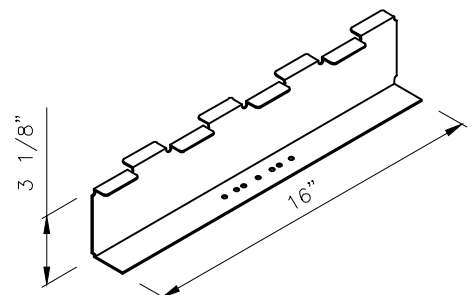

SUPER CLIP

3/8" Offset
16 GA.

Standard: Galvanized G90 - ASTM A653 (50 ksi)

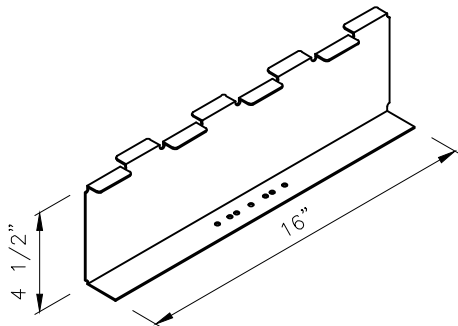

SUPER TALL CLIP

1 3/4" Offset
16 GA.

Standard: Galvanized G90 - ASTM A653 (50 ksi)

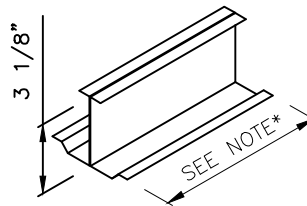

LOW MULTI-SPAN CLIP

3/8" Offset
2-Piece

Standard: 24 GA. - ASTM A792 (50 ksi)

Optional: 22 GA. - ASTM A792 (50 ksi)

*Sold in lengths up to 30'-0"

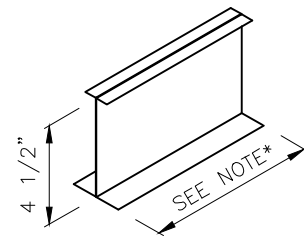

HIGH MULTI-SPAN CLIP

1 3/4" Offset
2-Piece

Standard: 24 GA. - ASTM A792 (50 ksi)

Optional: 22 GA. - ASTM A792 (50 ksi)

*Sold in lengths up to 30'-0"

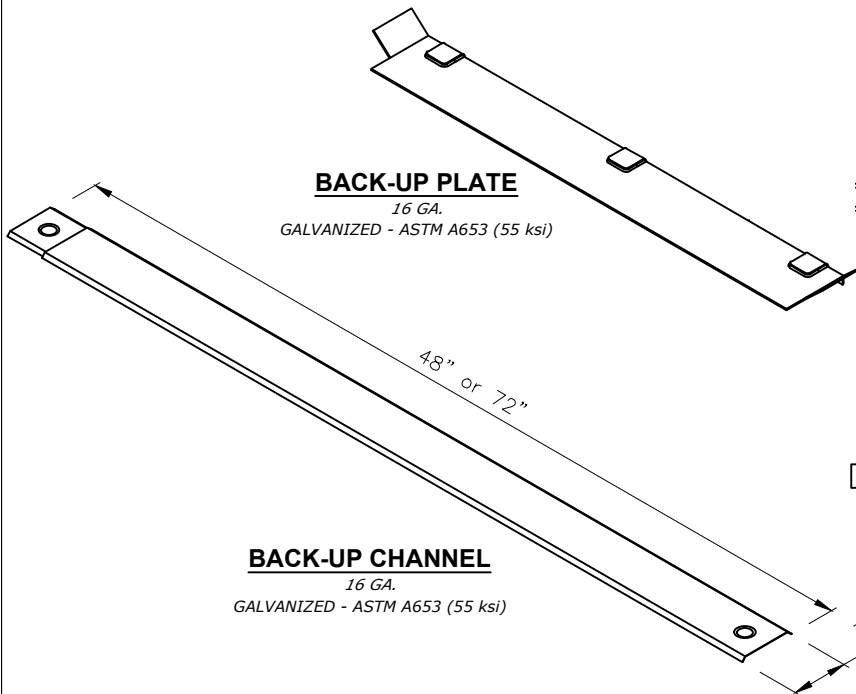

BACK-UP PLATE

16 GA.
GALVANIZED - ASTM A653 (55 ksi)

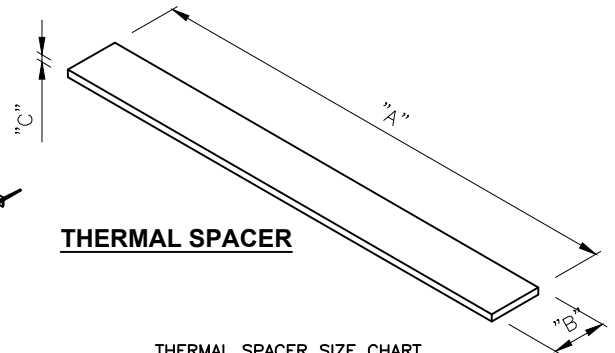

THERMAL SPACER

THERMAL SPACER SIZE CHART

PANEL	"A"	"B"	"C"
24"	22 7/8"	3"	3/8", 5/8", 1" or 1 3/8"

*NOTE: FOR 18" PANELS, FIELD CUT 22 7/8" SPACERS DOWN TO 16 7/8" LONG.

BACK-UP CHANNEL

16 GA.
GALVANIZED - ASTM A653 (55 ksi)