



DEPARTMENT OF REGULATORY AND ECONOMIC RESOURCES (RER)  
BOARD AND CODE ADMINISTRATION DIVISION

MIAMI-DADE COUNTY  
PRODUCT CONTROL SECTION  
11805 SW 26 Street, Room 208  
Miami, Florida 33175-2474  
T (786) 315-2590 F (786) 315-2599

[www.miamidade.gov/economy](http://www.miamidade.gov/economy)

**NOTICE OF ACCEPTANCE (NOA)**

McElroy Metal, Inc.  
1500 Hamilton Road  
Bossier City, LA 71111

**SCOPE:**

This NOA is being issued under the applicable rules and regulations governing the use of construction materials. The documentation submitted has been reviewed and accepted by Miami-Dade County RER- Product Control Section to be used in Miami Dade County and other areas where allowed by the Authority Having Jurisdiction (AHJ).

This NOA shall not be valid after the expiration date stated below. The Miami-Dade County Product Control Section (In Miami Dade County) and/or the AHJ (in areas other than Miami Dade County) reserve the right to have this product or material tested for quality assurance purposes. If this product or material fails to perform in the accepted manner, the manufacturer will incur the expense of such testing and the AHJ may immediately revoke, modify, or suspend the use of such product or material within their jurisdiction. RER reserves the right to revoke this acceptance, if it is determined by Miami-Dade County Product Control Section that this product or material fails to meet the requirements of the applicable building code.

This product is approved as described herein, and has been designed to comply with the High Velocity Hurricane Zone of the Florida Building Code.

**DESCRIPTION: "PBR-Panel" 0.023" (min.) Steel Structural Roof Panel**

**APPROVAL DOCUMENT:** Drawing No. E, titled "PBR - Roof Panel", sheets 1 through 5 of 5, prepared by McElroy Metal, Inc. Engineering Services Dept., signed and sealed by Johnathan Green, P.E. on January 27, 2021, bearing the Miami-Dade County Product Control Revision stamp with the Notice of Acceptance number and the expiration date by the Miami-Dade County Product Control Section.

**MISSILE IMPACT RATING: Large and Small Missile Impact Resistant**

**LABELING:** Each panel shall bear a permanent label with the manufacturer's name or logo:

1500 Hamilton Road	9700 Interstate 20	253 One Georgia Drive	460 Clay Road
Bossier City, LA 71111	Merkel, TX 79536	Ashburn, GA 31714	Sunnyvale, TX 75182

and the following statement: "Miami-Dade County Product Control Approved", unless otherwise noted herein.

**RENEWAL** of this NOA shall be considered after a renewal application has been filed and there has been no change in the applicable building code negatively affecting the performance of this product.

**TERMINATION** of this NOA will occur after the expiration date or if there has been a revision or change in the materials, use, and/or manufacture of the product or process. Misuse of this NOA as an endorsement of any product, for sales, advertising or any other purposes shall automatically terminate this NOA. Failure to comply with any section of this NOA shall be cause for termination and removal of NOA.

**ADVERTISEMENT:** The NOA number preceded by the words Miami-Dade County, Florida, and followed by the expiration date may be displayed in advertising literature. If any portion of the NOA is displayed, then it shall be done in its entirety.

**INSPECTION:** A copy of this entire NOA shall be provided to the user by the manufacturer or its distributors and shall be available for inspection at the job site at the request of the Building Official.

This NOA revises NOA #18-1015.07 and consists of this page 1, evidence submitted pages E-1, E-2, E-3, & E-4 and approval document mentioned above.

The submitted documentation was reviewed by **Helmy A. Makar, P.E., M.S.**



*Helmy A. Makar*  
02/18/2021

NOA No. 20-1215.11  
Expiration Date: 12/04/2023  
Approval Date: 02/18/2021

McElroy Metal, Inc.

NOTICE OF ACCEPTANCE: EVIDENCE SUBMITTED

**1. EVIDENCE SUBMITTED UNDER PREVIOUS APPROVAL #08-1007.06**

**A. DRAWINGS**

1. *Drawing No. E, titled "PBR - Roof Panel", sheets 1 through 5 of 5, prepared by McElroy Metal, Inc. Engineering Services Dept., signed and sealed by Terrence E. Wolfe, P.E. on October 29, 2008.*

**B. TESTS**

1. *Test report on Large Missile Impact Test on PBR Roof Panel, prepared by Farabaugh Engineering and Testing, Inc., Report No. T296-07, dated April 22, 2008, signed and sealed by Daniel G. Farabaugh, P.E.*
2. *Test report per ASTM 1592 on PBR Roof Panel, Report No. T232-08, dated August 25, 2008, prepared by Farabaugh Engineering and Testing, Inc., signed and sealed by Daniel G. Farabaugh, P.E.*
3. *Test report on Accelerated Weathering Testing of Coating 2000 hours per ASTM G26-96, prepared by PRI Asphalt Technologies, Report No. VLS-001-02-02, dated January 19, 2004, signed and sealed by Charles L. Thomas, P.E.*
4. *Test report on Salt Spray Testing of Coating 1000 hours per ASTM B117-95, prepared by PRI Asphalt Technologies, Report No. VLS-001-02-01, dated January 19, 2004, signed and sealed by Charles L. Thomas, P.E.*
5. *Susceptibility to leakage test in accordance with FM 4471, Appendix G, prepared by Farabaugh Engineering and Testing, Inc., Report No. T308-07, dated April 22, 2008, signed and sealed by Daniel G. Farabaugh, P.E.*

**C. CALCULATIONS**

1. *Calculations titled "PBR Panel, 24 Ga.", 6 pages, prepared by Terrence E. Wolfe, P.E., signed and sealed by Terrence E. Wolfe, P.E. on October 29, 2008.*

**D. QUALITY ASSURANCE**

1. *By Miami-Dade County Building Code Compliance Office.*

**E. MATERIAL CERTIFICATIONS**

1. *Tensile Test, prepared by West Penn Material Evaluation, dated September 12, 2007.*

**2. EVIDENCE SUBMITTED UNDER PREVIOUS APPROVAL # 09-0504.07**

**A. DRAWINGS**

1. *None.*

**B. TESTS**

1. *None.*

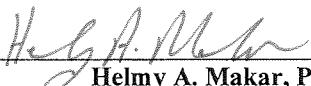
  
\_\_\_\_\_  
Helmy A. Makar, P.E., M.S.  
Product Control Section Supervisor  
NOA No. 20-1215.11  
Expiration Date: 12/04/2023  
Approval Date: 02/18/2021

McElroy Metal, Inc.

NOTICE OF ACCEPTANCE: EVIDENCE SUBMITTED

**C. CALCULATIONS**

1. *None.*

**D. QUALITY ASSURANCE**

1. *By Miami-Dade County Building Code Compliance Office.*

**E. MATERIAL CERTIFICATIONS**

1. *None.*

**3. EVIDENCE SUBMITTED UNDER PREVIOUS APPROVAL # 13-1024.02**

**A. DRAWINGS**

1. *None.*

**B. TESTS**

1. *None.*

**C. CALCULATIONS**

1. *None.*

**D. QUALITY ASSURANCE**

1. *By Miami-Dade County Department of Regulatory and Economic Resources.*

**E. MATERIAL CERTIFICATIONS**

1. *None.*

**F. STATEMENTS**

1. *Letter of compliance with the Florida Building Code, 2010 Edition, prepared by Force Engineering & Testing, Inc., dated October 04, 2013, signed and sealed by Terrence E. Wolfe, P.E.*

**4. EVIDENCE SUBMITTED UNDER PREVIOUS APPROVAL # 15-1013.07**

**A. DRAWINGS**

1. *None.*

**B. TESTS**

1. *None.*

**C. CALCULATIONS**

1. *None.*

**D. QUALITY ASSURANCE**

1. *By Miami-Dade County Department of Regulatory and Economic Resources.*

  
\_\_\_\_\_  
Helmy A. Makar, P.E., M.S.

Product Control Section Supervisor

NOA No. 20-1215.11

Expiration Date: 12/04/2023

Approval Date: 02/18/2021

McElroy Metal, Inc.

NOTICE OF ACCEPTANCE: EVIDENCE SUBMITTED

**E. MATERIAL CERTIFICATIONS**

1. *None.*

**F. STATEMENTS**

1. *Letter of compliance with the Florida Building Code, 2014 Edition, prepared by Force Engineering & Testing, Inc., dated September 08, 2015, signed and sealed by Terrence E. Wolfe, P.E.*

**5. EVIDENCE SUBMITTED UNDER PREVIOUS APPROVAL # 17-0829.04**

**A. DRAWINGS**

1. *None.*

**B. TESTS**

1. *None.*

**C. CALCULATIONS**

1. *None.*

**D. QUALITY ASSURANCE**

1. *By Miami-Dade County Department of Regulatory and Economic Resources.*

**E. MATERIAL CERTIFICATIONS**

1. *None.*

**F. STATEMENTS**

1. *Letter of compliance with the Florida Building Code, 2017 Edition, prepared by Force Engineering & Testing, Inc., dated 08/14/2017, signed and sealed by Terrence E. Wolfe, P.E.*

**6. EVIDENCE SUBMITTED UNDER PREVIOUS APPROVAL # 18-1015.07**

**A. DRAWINGS**

1. *None.*

**B. TESTS**

1. *Test report on Accelerated Weathering Testing of Coating 2000 hours per ASTM G26-96, prepared by PRI Asphalt Technologies, Report No. VLS-004-02-01, dated February 22, 2013, signed and sealed by Zachary R. Priest, P.E.*

2. *Test report on Salt Spray Testing of Coating 1000 hours per ASTM B117-95, prepared by PRI Asphalt Technologies, Report No. VLS-005-02-01, dated February 22, 2013, signed and sealed by Zachary R. Priest, P.E.*

  
Helmy A. Makar, P.E., M.S.

Product Control Section Supervisor

NOA No. 20-1215.11

Expiration Date: 12/04/2023

Approval Date: 02/18/2021

McElroy Metal, Inc.

NOTICE OF ACCEPTANCE: EVIDENCE SUBMITTED

**C. CALCULATIONS**

1. *None.*

**D. QUALITY ASSURANCE**

1. *By Miami-Dade County Department of Regulatory and Economic Resources.*

**E. MATERIAL CERTIFICATIONS**

1. *Tensile Test, prepared by Intertek, Report # G9475.02-106-18, dated May 10, 2017, signed and sealed by Joseph A. Reed, P.E.*

**F. STATEMENTS**

1. *Letter of compliance with the Florida Building Code, 2017 Edition, prepared by Force Engineering & Testing, Inc., dated 10/03/2018, signed and sealed by Terrence E. Wolfe, P.E.*

**7. NEW EVIDENCE SUBMITTED**

**A. DRAWINGS**

1. *Drawing No. E, titled " PBR - Roof Panel ", sheets 1 through 5 of 5, prepared by McElroy Metal, Inc. Engineering Services Dept., signed and sealed by Johnathan Green, P.E. on January 27, 2021.*

**B. TESTS**

1. *None.*

**C. CALCULATIONS**

1. *None.*

**D. QUALITY ASSURANCE**

1. *By Miami-Dade County Department of Regulatory and Economic Resources.*

**E. MATERIAL CERTIFICATIONS**

1. *None.*

**F. STATEMENTS**

1. *Letter of compliance with the Florida Building Code, 2020 Edition, prepared by Force Engineering & Testing, Inc., dated 11/12/2020, signed and sealed by Johnathan Green, P.E.*

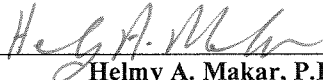
  
\_\_\_\_\_  
Helmy A. Makar, P.E., M.S.  
Product Control Section Supervisor  
NOA No. 20-1215.11  
Expiration Date: 12/04/2023  
Approval Date: 02/18/2021

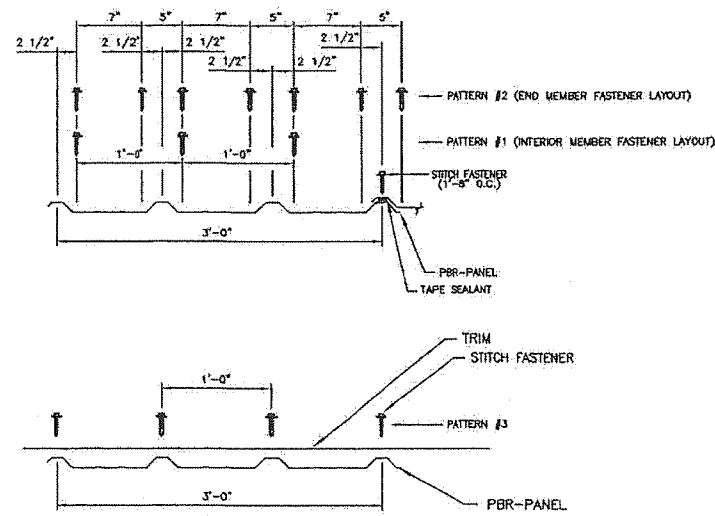

R-PANEL FRAMING AND TRIM SCREW PATTERNS.

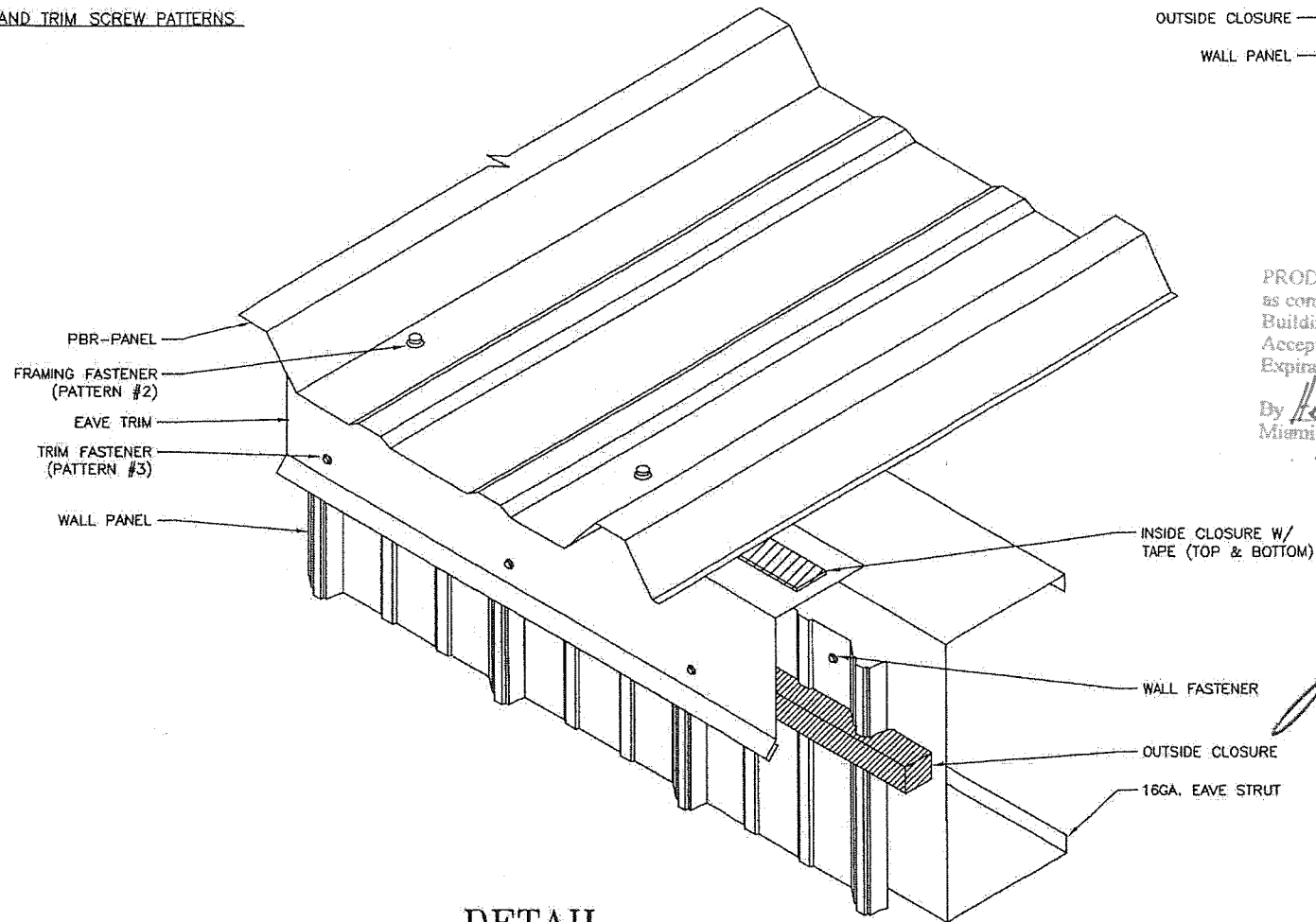

DETAIL  
@ EAVE  
(ISOMETRIC VIEW)

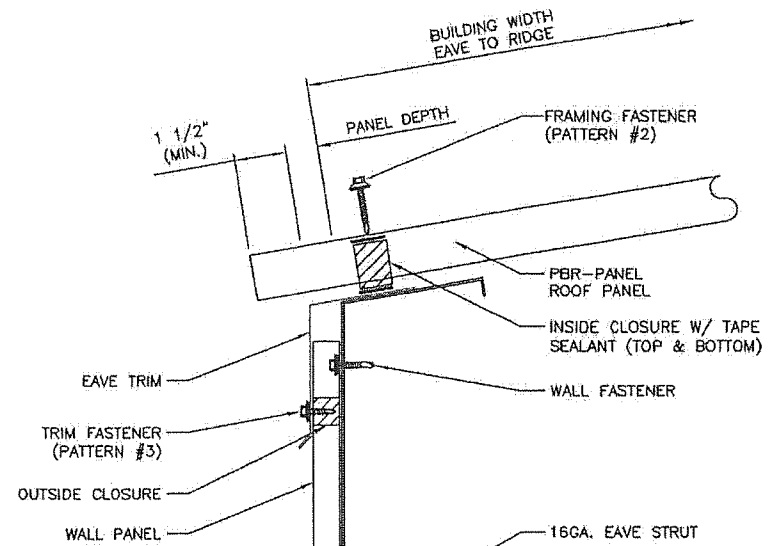

DETAIL  
@ EAVE

PRODUCT REVISED  
as complying with the Florida  
Building Code  
Acceptance No 20-1215.11  
Expiration Date 12/04/2023  
By *Helga...*  
Miami Date Product Control

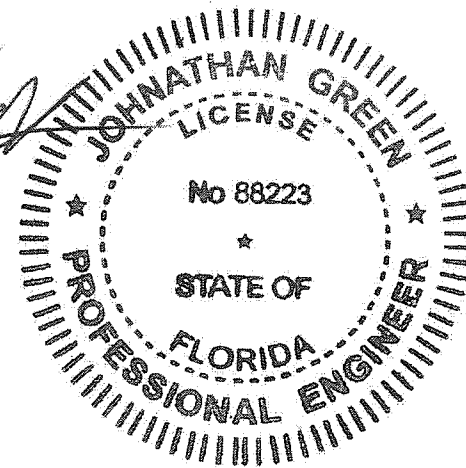

FOR CONSTRUCTION

McELROY METAL, INC  
ENGINEERING SERVICES DEPT.  
1800 HAMILTON ROAD - BOSSIER CITY, LA. (504) 747-8000



DADE COUNTY TESTING  
PBR-PANEL WATERHEAD TEST  
McELROY METAL, INC.

SCALE: N.T.S.

DATE: 1/27/2021

DWN. BY: J. PURDY

CHKD BY: E. OSTER

LOG NO:

E1 of 5

DATE: 1/27/2021

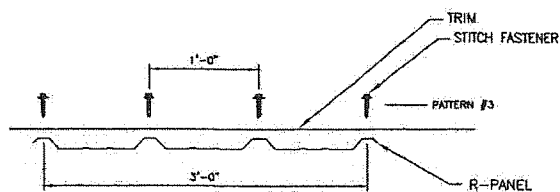
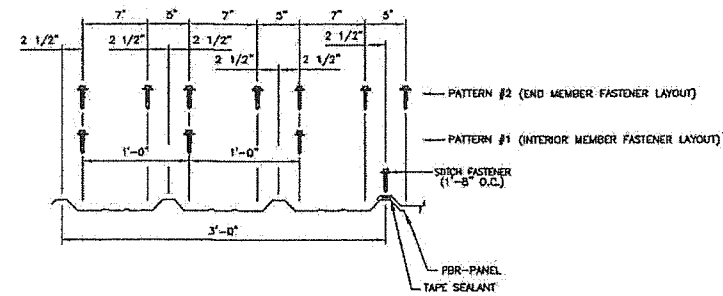

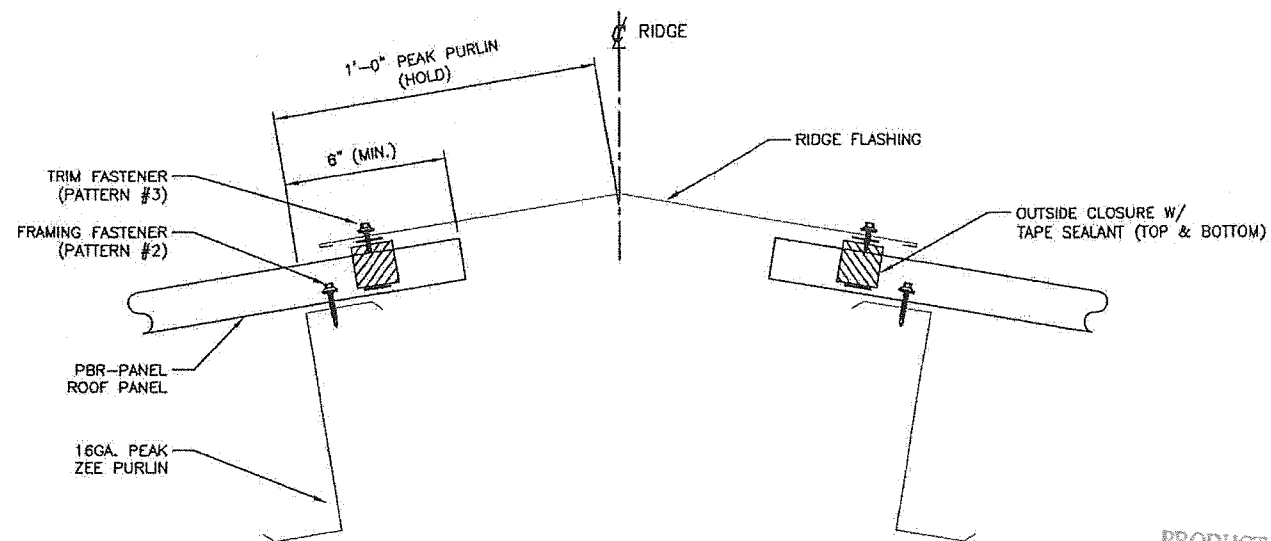

R-PANEL FRAMING AND TRIM SCREW PATTERNS

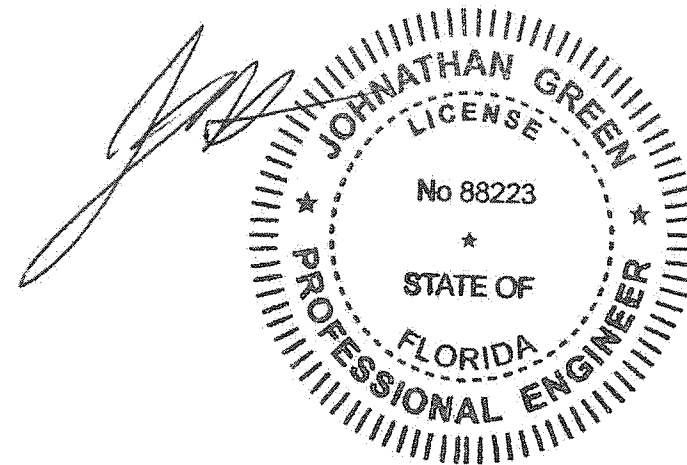

DETAIL  
@ RIDGE

PRODUCT REVISED  
as complying with the Florida  
Building Code  
Acceptance No 20-1215.11  
Expiration Date 12/04/2023  
By *Heidi A. Walker*  
Miami Dade Product Control



MCELROY METAL, INC ENGINEERING SERVICES DEPT. 1800 HAMILTON ROAD - BOSSIER CITY, LA. (504) 747-9000	
	
DADE COUNTY TESTING PBR-PANEL WATERHEAD TEST MCELROY METAL, INC.	
SCALE: N.T.S.	
DATE: 1/27/2021	
DWN BY: J. PURDY	
CHKD BY: E. OSTEL	
LOG NO:	
E2 OF 5	
DATE: 01/27/2021	BY: B

FOR CONSTRUCTION

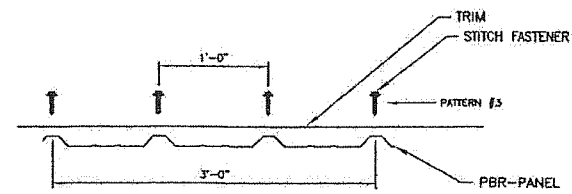
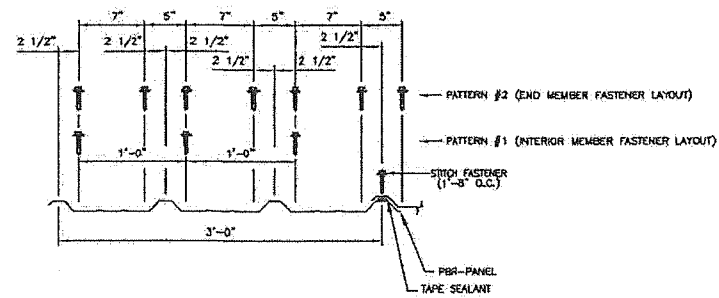

R-PANEL FRAMING AND TRIM SCREW PATTERNS

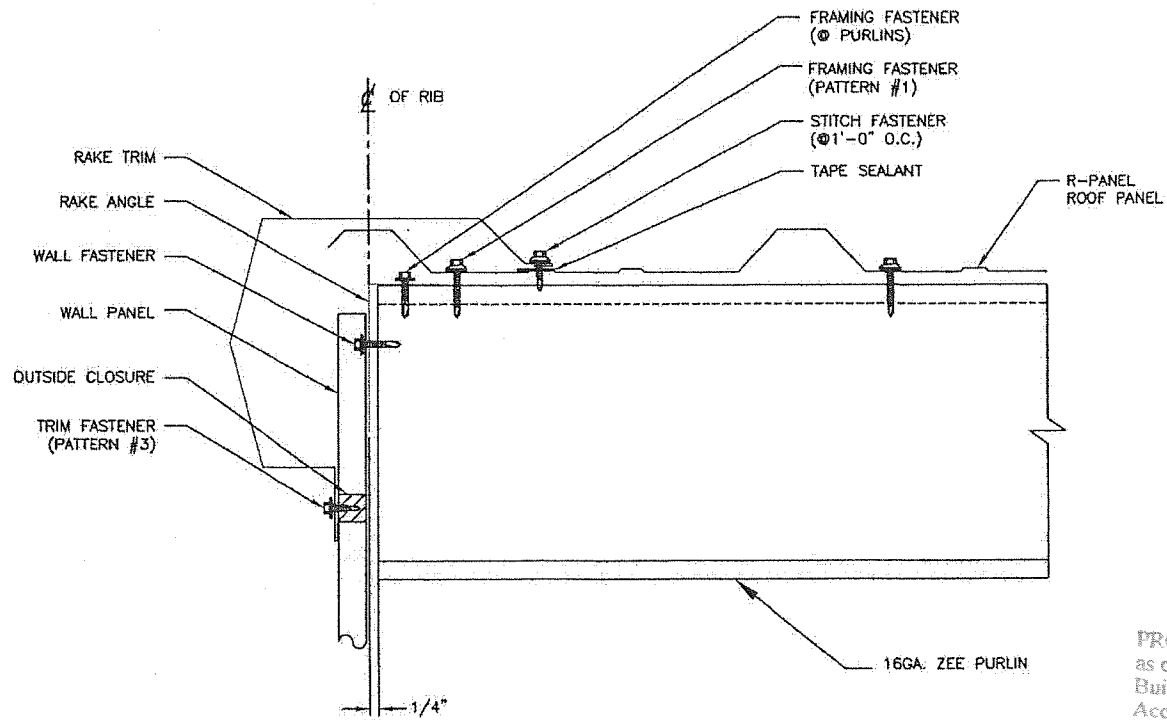

DETAIL @ RAKE

PRODUCT REVISED  
 as complying with the Florida  
 Building Code  
 Acceptance No 20-1215.11  
 Expiration Date 12/04/2023  
 By *Heidi A. Plator*  
 Miami Date Product Control

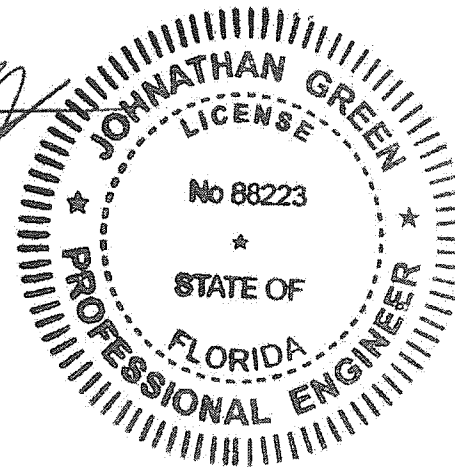

McELROY METAL, INC  
 ENGINEERING SERVICES DEPT.  
 1800 HAMILTON ROAD - BOSSIER CITY, LA. (918) 747-8000



DADE COUNTY TESTING  
 PBR-PANEL WATERHEAD TEST  
 McELROY METAL, INC.

SCALE: N.T.S.

DATE: 1/27/2021

DWN. BY: J. PURDY

CHKD BY: E. OSTEI

LOG NO. \_\_\_\_\_

E3 of 5

DATE: 1/27/2021

B

FOR CONSTRUCTION



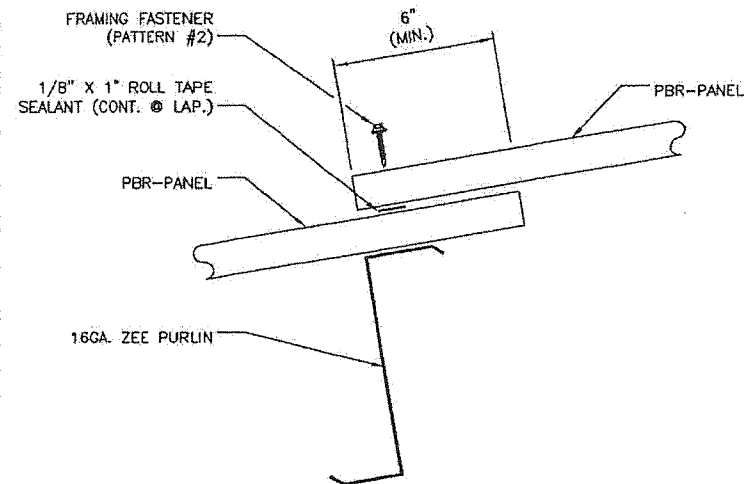

DETAIL  
@ PANEL LAP

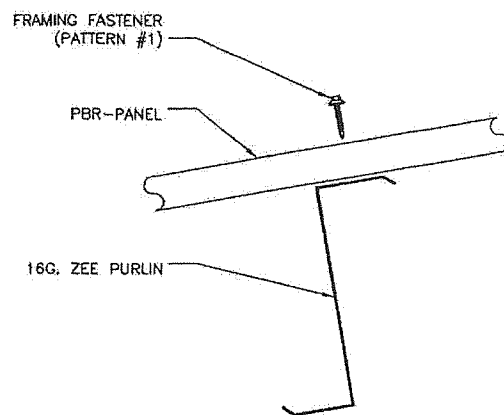

DETAIL  
@ ITERMEDIATE PURLIN

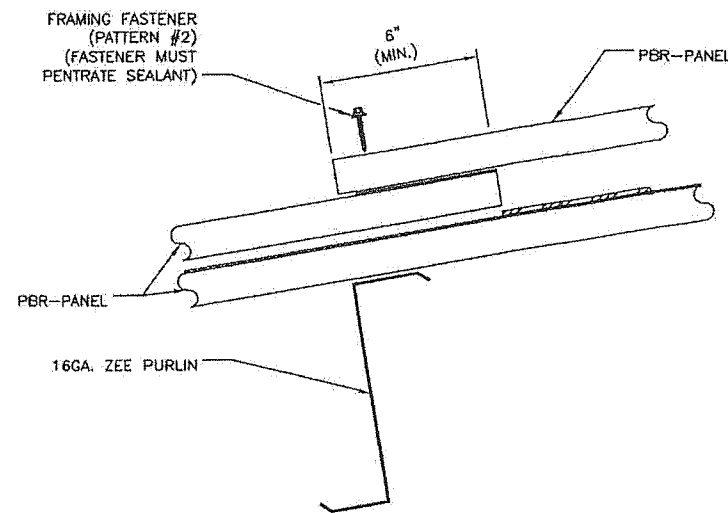

DETAIL A1

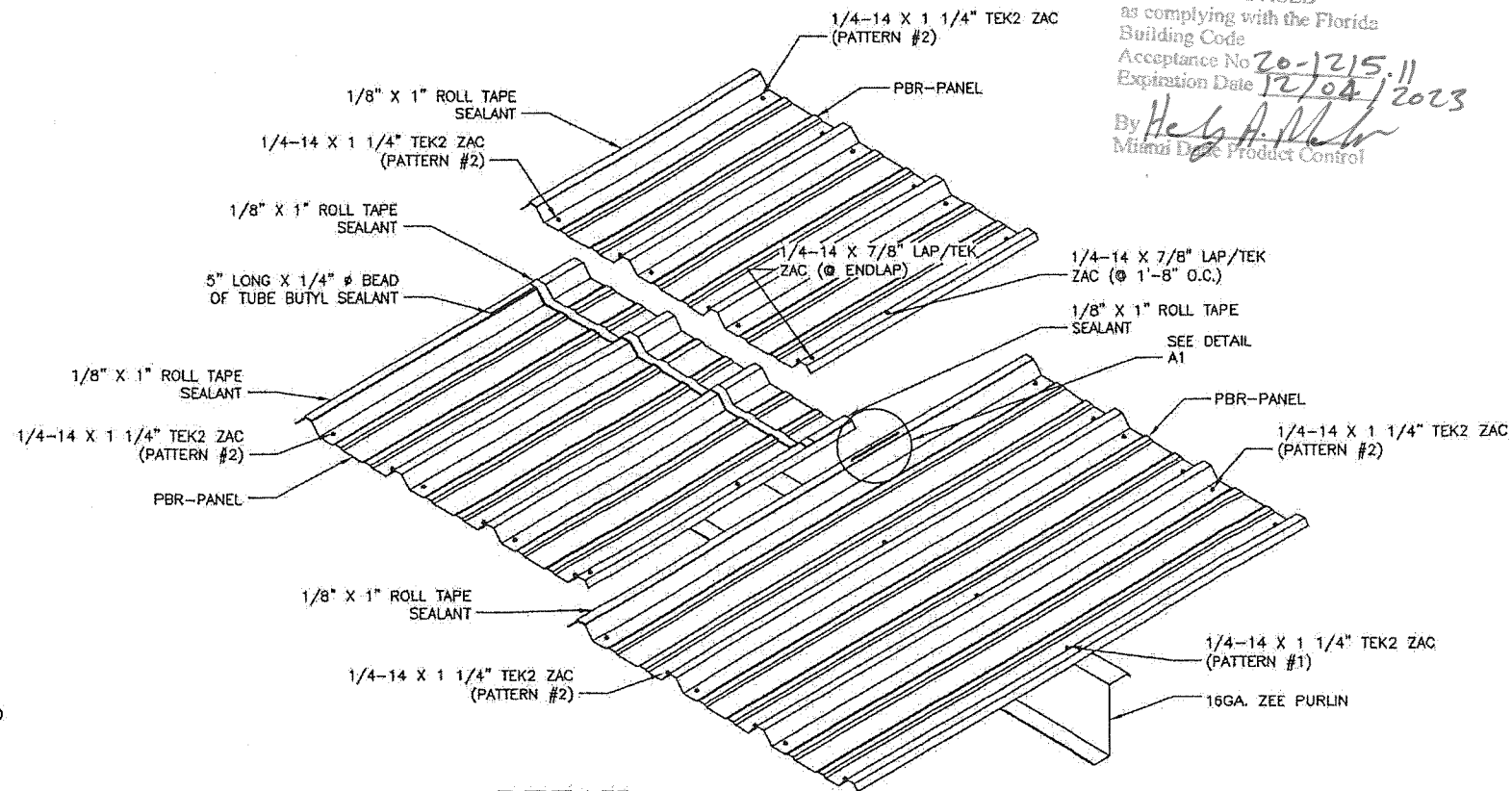
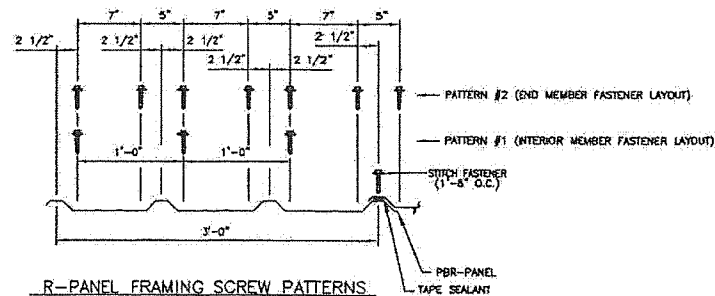
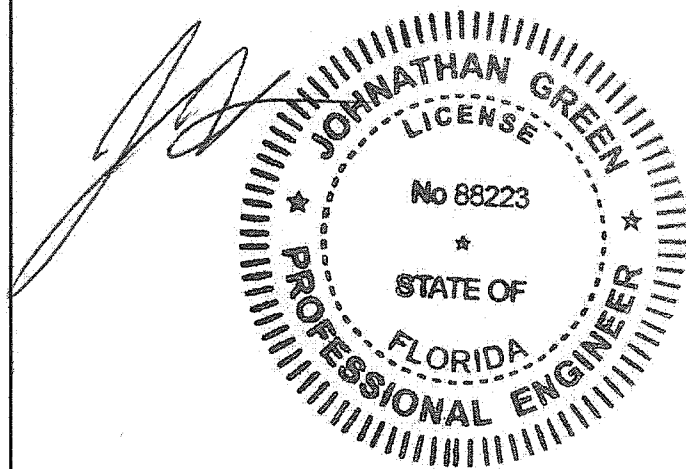

DETAIL  
@ PANEL LAP  
(ISOMETRIC)

PRODUCT REVISED  
as complying with the Florida  
Building Code  
Acceptance No 20-1215.11  
Expiration Date 12/04/2023  
By *Heidi A. McElroy*  
Miami Date Product Control

	
<b>McELROY METAL, INC.</b> ENGINEERING SERVICES DEPT. <small>1800 HAMILTON ROAD - BOSSIER CITY, LA. (504) 747-9000</small>	
DADE COUNTY TESTING PBR-PANEL WATERHEAD TEST McELROY METAL, INC.	
SCALE: N.T.S.	
DATE: 1/27/2021	
DWN. BY: J. PURDY	
CHKD BY: E. OSTEF	
LOG NO: _____	
E4 OF 5	
B	

FOR CONSTRUCTION

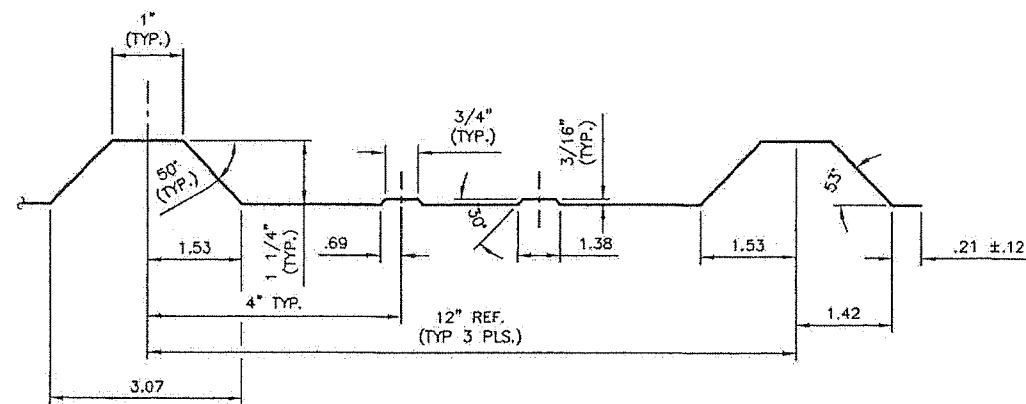

**NOTES:**

1. THE MAXIMUM UPLIFT DESIGN PRESSURE SHALL BE CALCULATED USING THE FOLLOWING ALLOWABLES.

- POSITIVE PRESSURE

A) MAXIMUM ALLOWABLE BENDING MOMENT OF THE PANEL AT SUPPORTS = 119.75 FT. LB.  
 B) MAXIMUM ALLOWABLE BENDING MOMENT OF THE PANEL BETWEEN SUPPORTS = 95.8 FT. LB.  
 C) MAXIMUM ALLOWABLE DEFLECTION OF ROOF PANEL = L/240  
 D) MAXIMUM SUPPORT REACTION = 85.8 LBS. EXT.  
 E) MAXIMUM SUPPORT REACTION = 263.43 LBS. INT.  
 E)  $EI = 1.4276 \times 10^8 \text{ LB-IN}^2$

- NEGATIVE PRESSURE

A) MAXIMUM ALLOWABLE BENDING MOMENT OF THE PANEL AT SUPPORTS = 106.75 FT. LB.  
 B) MAXIMUM ALLOWABLE BENDING MOMENT OF THE PANEL BETWEEN SUPPORTS = 85.4 FT. LB.  
 C) MAXIMUM ALLOWABLE DEFLECTION OF ROOF PANEL = L/240  
 D) MAXIMUM SUPPORT REACTION = 85.4 LBS. EXT.  
 E) MAXIMUM SUPPORT REACTION = 234.85 LBS. INT.  
 E)  $EI = 1.2728 \times 10^8 \text{ LB-IN}^2$

2. THE MAXIMUM ALLOWABLE SPANS & PRESSURES ARE AS FOLLOWS:

- POSITIVE PRESSURE

SPAN	PRESSURE
5'-0"	47.9 PSF
2'-0"	156.65 PSF

- NEGATIVE PRESSURE

SPAN	PRESSURE
5'-0"	42.7 PSF
2'-0"	117.65 PSF

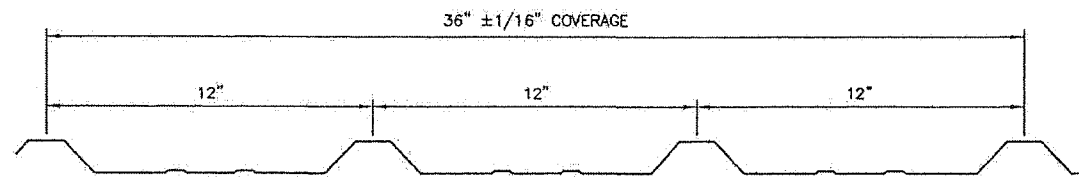

**PBR-PANEL**

PRODUCT REVISED  
 as complying with the Florida  
 Building Code  
 Acceptance No 20-1215.11  
 Expiration Date 12/04/2023  
 By *Heidi A. M...*  
 Miami Dade Product Control

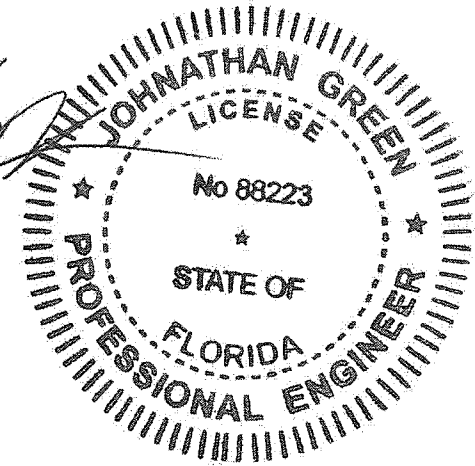

**PANEL ACCESSORIES**

- 1/4-14 X 7/8" LAF/TEK ZAC  
By: SFS INTEC  
\* SEE NOTE BELOW
  - 1/4-14 X 1 1/4" TEK2 ZAC  
By: SFS INTEC  
\* SEE NOTE BELOW
  - SKALASTOMER 511 TUBE SEALANT  
By: SKA
  - SKAFLEX 201 URETHANE TUBE SEALANT  
By: SKA
  - 1/8" X 1" BUTYL ROLL TAPE SEALANT  
By: SCHNEE-MOREHEAD
- NOTE:**  
 ZAC IS A ZINC ALUMINUM CAP  
 WITH A 5/8" DIA. NEOPRENE  
 SEALING WASHER.

**PANEL PROPERTIES**

ASTM	PANEL GAUGE	PANEL THICKNESS	YEILD STRENGTH	TENSILE STRENGTH	STEEL COATING	PAINT COATINGS
A792	24	.023 (MIN.)	50 KSI (MIN.)	65 KSI (MIN.)	AZ 55 (BARE) AZ 50 (PAINTED)	KYNAR 500

**FOR CONSTRUCTION**

**McELROY METAL, INC**  
 ENGINEERING SERVICES DEPT.  
 1500 HAMILTON ROAD - BOSSIER CITY, LA. (504) 747-8000



DADE COUNTY TESTING  
 PBR-PANEL WATERHEAD TEST  
 McELROY METAL, INC.

SCALE: N.T.S.  
 DATE: 1/27/2021  
 DWN. BY: J. PURDY  
 CHKD BY: E. GSTEI  
 LOG NO: \_\_\_\_\_  
 E5 of 5  
 B