



# INSTALLATION MANUAL



McElroy Metal, Inc.



# MEDALLION I

Medallion-I is a concealed fastener architectural batten cap roof system. The Medallion-I panels are easily installed over decking utilizing metal clips. Medallion-I systems are ideally suited for decorative mansard, fascia and roofs.

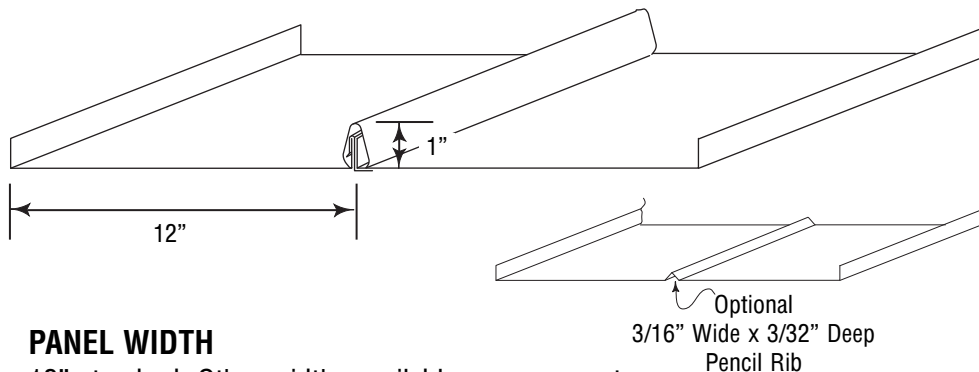

**PANEL WIDTH**  
12" standard. Other widths available upon request.

**COVER WIDTH**  
12" standard

**SUBSTRATE**  
24 Gauge Galvalume

**PANEL LENGTH**  
40' Maximum  
3' 9" Minimum

**CLIP SPACING**  
2 Ft. Maximum center

**BATTEN CAP HEIGHT**  
1"

**MINIMUM SLOPE**  
3:12 Pitch

**AIR AND WATER INFILTRATION**  
Medallion-I systems have been tested in accordance with ASTM E283-91, ASTM E331-86, ASTM E1680 and ASTM E1646 procedures.

**WIND UPLIFT CLASS 90**  
Medallion-I system is UL-90 rated in accordance with UL construction #280 and UL construction #310.



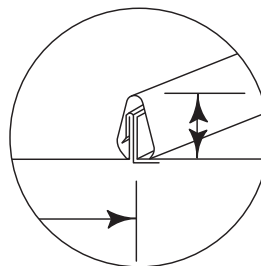





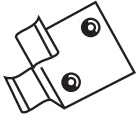
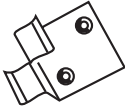
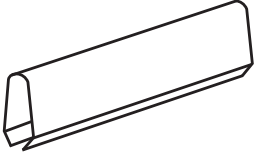
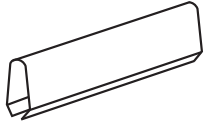
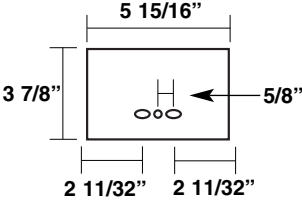

Oil canning (pan wave) of metal panels is inherent in the product and is not cause for panel rejection.



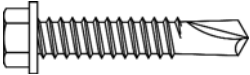

# MEDALLION I



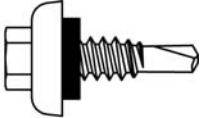
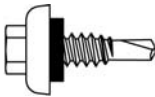





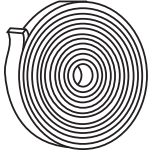
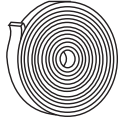
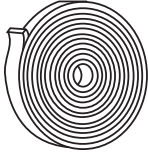

## ACCESSORIES

	<p><b>Material: 26 Ga.</b> <b>Length: N/A</b></p>	 <b>Medallion I Clip</b> <b>Item #: 36500</b>
	<p><b>Material: 24 Ga.</b> <b>Length: Varies</b></p>	 <b>Medallion I Batten</b>
	<p><b>Material: 16 Ga.</b> <b>Length: 5 15/16"</b></p>	 <b>Bearing Plate</b> <b>Primed Item #: 94599</b> <b>Galvanized Item #: 203541</b>
	<p><b>Material: N/A</b> <b>Length: 1"</b></p>	 <b>#9 - 15 x 1" Woodgrip</b> <b>W/O Washer - Plain</b> <b>Item #: 36115</b>
	<p><b>Material: N/A</b> <b>Length: 1 1/4"</b></p>	 <b>1/4 - 14 x 1 1/4" TEK2</b> <b>W/O Washer - Plain</b> <b>Item #: 10969</b>
	<p><b>Material: N/A</b> <b>Length: 1"</b></p>	 <b>#10 - 12 x 1" Type A</b> <b>Pancake Head</b> <b>Woodgrip</b> <b>Item #: 36116</b>
	<p><b>Material: N/A</b> <b>Length: 1"</b></p>	 <b>#10 - 16 x 1" TEK 2</b> <b>Pancake Head</b> <b>Self-Driller</b> <b>Item #: 36117</b>
	<p><b>Material: N/A</b> <b>Length: 7/8"</b></p>	 <b>1/4 - 14 x 7/8"</b> <b>LAPTEK ZAC</b> <b>Self-Driller</b> <b>(Part # Varies by Color)</b>



# MEDALLION I ACCESSORIES

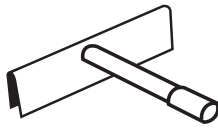

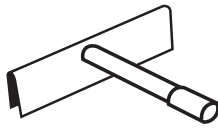
	<p><b>Material: 1/8" Diameter Stainless Steel Length: 5/16"</b></p>	
<p><b>43D PopRivets (Part # Varies by Color)</b></p>		
	<p><b>Material: N/A Length: 45'</b></p>	
<p><b>Roll Tape Sealant 3/32" x 1" x 45' Item #: 95335</b></p>		
	<p><b>Material: N/A Length: N/A</b></p>	
<p><b>White Urethane Sealant Item #: 95320</b></p>		
	<p><b>Material: N/A Length: N/A</b></p>	
<p><b>Butyl Tube Sealant Item #: 95342</b></p>		
	<p><b>Material: N/A Length: N/A</b></p>	
<p><b>Touch-Up Paint Pen (Part # Varies by Color)</b></p>		<p><b>Notes:</b></p>
<p><b>Hemming Tool Item #: 36120</b></p>		





# MEDALLION I



## TRIM

	<p><b>Material: 24 Ga.</b>  <b>Length: 10' 3"</b>  <b>20' 3"</b></p>	<p><b>Soffit Base Trim</b></p>
	<p><b>Material: 24 Ga.</b>  <b>Length: 5' 3"</b>  <b>10' 3"</b></p>	<p><b>Outside Corner</b></p>
	<p><b>Material: 24 Ga.</b>  <b>Length: 5' 3"</b>  <b>10' 3"</b></p>	<p><b>Inside Corner</b></p>
	<p><b>Material: 24 Ga.</b>  <b>Length: 10' 3"</b>  <b>20' 3"</b></p>	<p><b>Eave Trim*</b>  <b>*specify roof pitch</b></p>
	<p><b>Material: 24 Ga.</b>  <b>Length: 10' 3"</b>  <b>20' 3"</b></p>	<p><b>Eave Drip Trim*</b>  <b>*specify roof pitch</b></p>
	<p><b>Material: 24 Ga.</b>  <b>Length: 10'</b></p>	<p><b>Perimeter Cleat</b></p>



# MEDALLION I TRIM

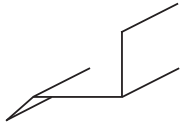
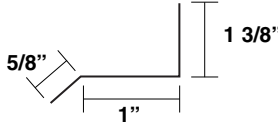
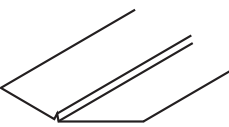
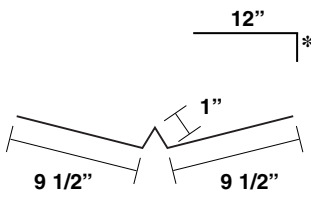

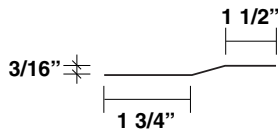
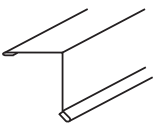
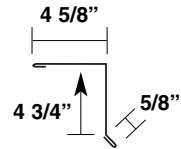
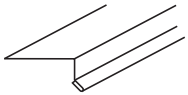
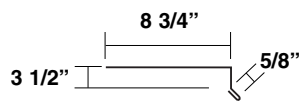
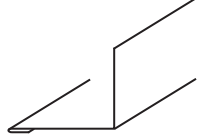
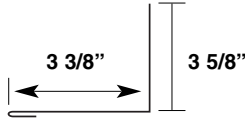
	<p><b>Material: 24 Ga.</b> <b>Length: 10'</b></p>	
<p><b>Perimeter Zee Trim</b></p>		
	<p><b>Material: 24 Ga.</b> <b>Length: 10' 3\"</b></p>	
<p><b>Valley Trim*</b> <b>*specify roof pitch</b></p>		
	<p><b>Material: 24 Ga.</b> <b>Length: 10'</b></p>	
<p><b>Offset Cleat</b></p>		
	<p><b>Material: 24 Ga.</b> <b>Length: 10' 3\"</b></p>	
<p><b>Rake Trim</b></p>		
	<p><b>Material: 24 Ga.</b> <b>Length: 10' 3\"</b></p>	
<p><b>Rake Trim Alternative</b></p>		
	<p><b>Material: 24 Ga.</b> <b>Length: 10' 3\"</b></p>	
<p><b>Rake Tie-In Trim</b></p>		





# MEDALLION I



## TRIM

	<p><b>Material: 24 Ga.</b> <b>Length: 10'</b></p>	<p><b>Zee Closure</b></p>
	<p><b>Material: 24 Ga.</b> <b>Length: 10' 3"</b> <b>20' 3"</b></p>	<p><b>Hi-Side Trim*</b> <b>*specify roof pitch</b></p>
	<p><b>Material: 24 Ga.</b> <b>Length: 10' 3"</b></p>	<p><b>Highside Tie-In Trim*</b> <b>*specify roof pitch</b></p>
	<p><b>Material: 24 Ga.</b> <b>Length: 10' 3"</b> <b>20' 3"</b></p>	<p><b>Hip Flashing*</b> <b>*specify roof pitch</b></p>
	<p><b>Material: 24 Ga.</b> <b>Length: 10' 3"</b> <b>20' 3"</b></p>	<p><b>Ridge Flashing*</b> <b>*specify roof pitch</b></p>
	<p><b>Material: 24 Ga.</b> <b>Length: 10' 3"</b> <b>20' 3"</b></p>	<p><b>Gutter Trim*</b> <b>*specify roof pitch</b> <b>(Snow guards should be used to prevent damage from sliding snow.)</b></p>



# MEDALLION I TRIM

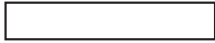
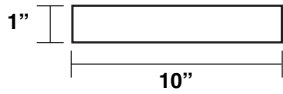
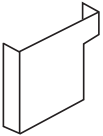
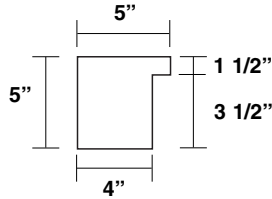

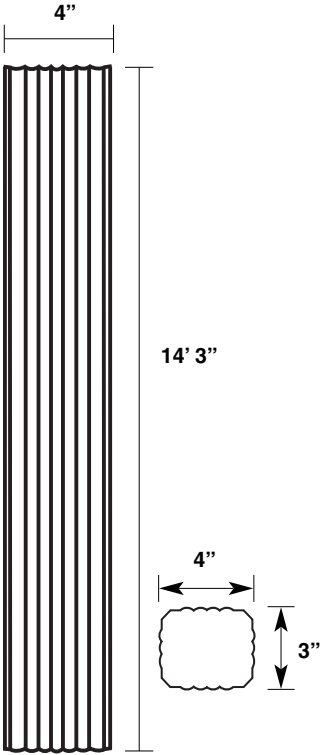
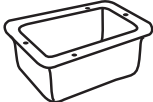
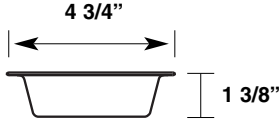
	<p><b>Material: 24 Ga.</b> <b>Length: 10"</b></p>	
<p><b>Gutter Strap</b></p>		
	<p><b>Material: 24 Ga.</b> <b>Length: N/A</b></p>	
<p><b>Gutter End Cap</b></p>		
	<p><b>Material: 26 Ga.</b> <b>Length: 14' 3"</b></p>	
<p><b>3" x 4" Downspout</b></p>		
	<p><b>Material: 26 Ga.</b> <b>Length: N/A</b></p>	
<p><b>Aluminum Downspout Outlet Box</b></p>		







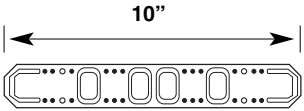

# MEDALLION I

## TRIM

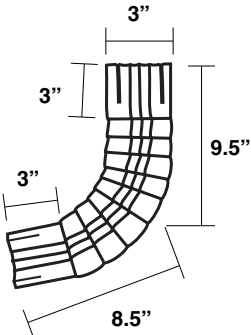
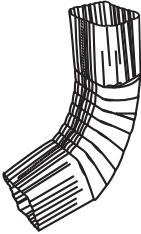
	<p><b>Material: 26 Ga.</b> <b>Length: N/A</b></p>	 <p><b>Downspout Strap</b></p>
	<p><b>Material: 26 Ga.</b> <b>Length: N/A</b></p>	 <p><b>3" X 4"</b> <b>Downspout Elbow</b> <b>A-Style</b></p>

Notes:

Blank area for notes.



# ◆ ◆ ◆ ◆ N O T E S ◆ ◆ ◆ ◆

The details shown on the following pages are suggestions or guidelines for installing the Medallion I system. The installation details shown here are proven methods of construction, but they are not intended to cover all building requirements, designs or codes. The details may require changes or revisions due to individual project conditions.

Installation procedures shall be in accordance with the manufacturer's printed instructions, details or approved shop drawings. Installers should thoroughly familiarize themselves with all instructions prior to beginning the installation process.

The designer/installer is responsible to ensure the following:

- That the details here meet the particular building requirements.
- Awareness of and allowance for expansion / contraction of the roof panels.
- That adequate water tightness is maintained.
- That a proper uniform substructure is used to avoid panel distortion and that the substructure meets necessary code requirements.
- That all supporting members have been examined and are straight, level, and plumb.

McElroy Metal can provide all flashings and accessories shown in the installation drawings unless noted otherwise. Panels, flashing and trim shall be installed true and in proper alignment with any exposed fasteners equally spaced for the best appearance. Sealant shall be field applied on a clean, dry surface.

Some field cutting and fitting of panels and flashings is to be expected and to be considered a part of normal installation work. Workmanship shall be of the best industry standards with installation performed by experienced metal craftsmen.

Oil canning of metal panels is inherent in the product and is not a cause for rejection. Striated panels are recommended as they reduce the appearance of oil canning.

Contents of this manual are subject to change without notice. To confirm this book is the most current copy, please visit McElroy Metal's website at [www.mcelroymetal.com](http://www.mcelroymetal.com).



◆ ◆ ◆ ◆ **Medallion I** ◆ ◆ ◆ ◆

**BATTEN**

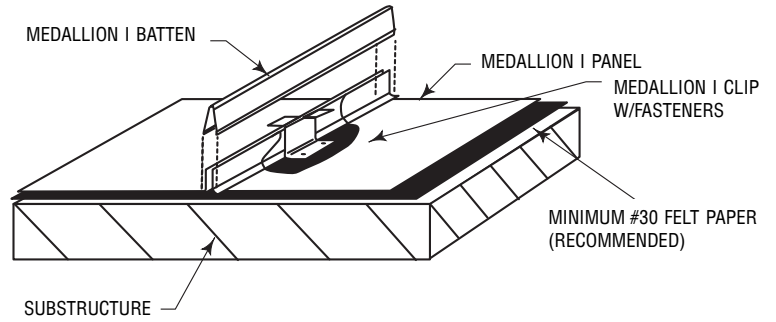

**BATTEN INSTALLATION DETAIL**

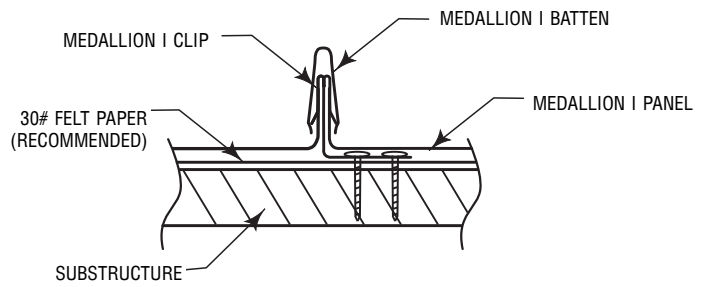

**INSTALLED PANEL CROSS SECTION**

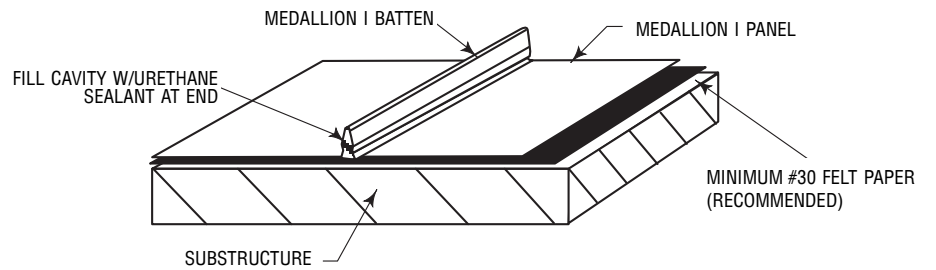

**BATTEN END DETAIL**



# ♦ ♦ ♦ ♦ Medallion I ♦ ♦ ♦ ♦

## PANEL HEMMING TOOL

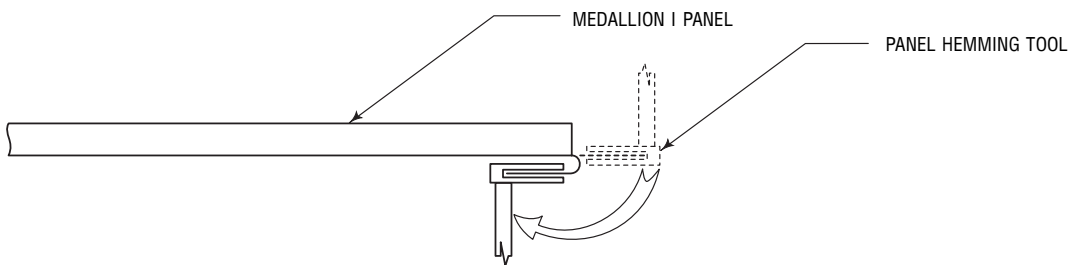
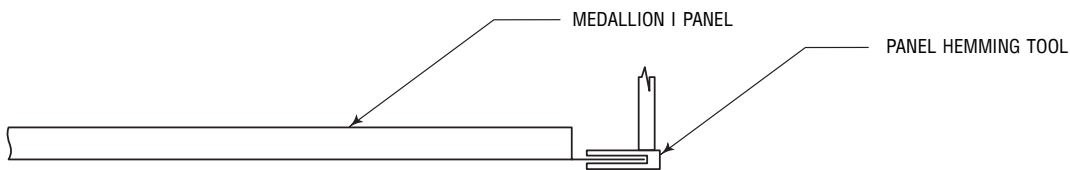
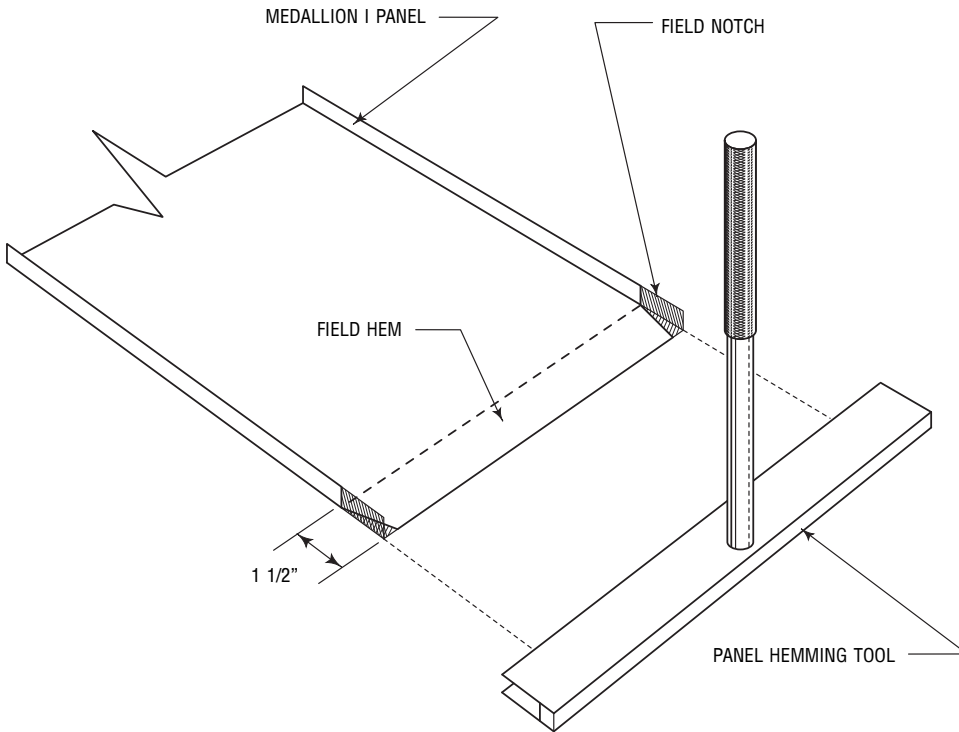

### NOTES:

1. Cut through male and female legs/ribs 1 1/2" up from panel end as shown.
2. Then cut diagonally with metal shears as shown.
3. Place hemming tool over panel tab.
4. Bend down and under to 180° as shown.

***When the eave drip trim condition is used, the panel lengths need to be 3/4" longer than panels used for offset cleat condition.***



# ◆ ◆ ◆ ◆ Medallion I ◆ ◆ ◆ ◆

## WALL SOFFIT BASE

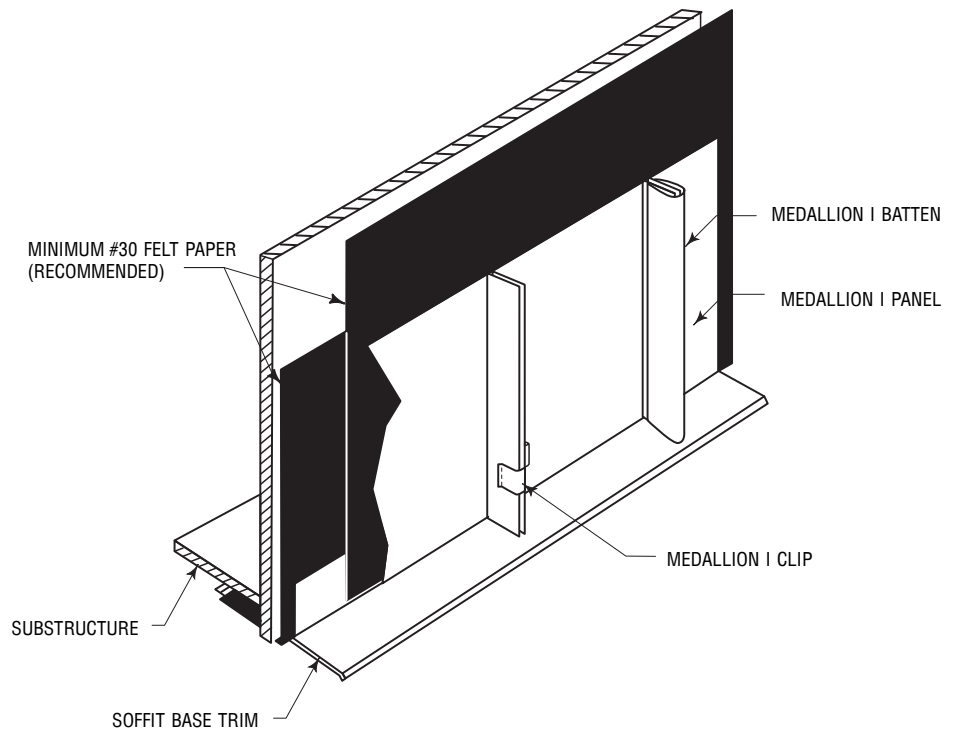
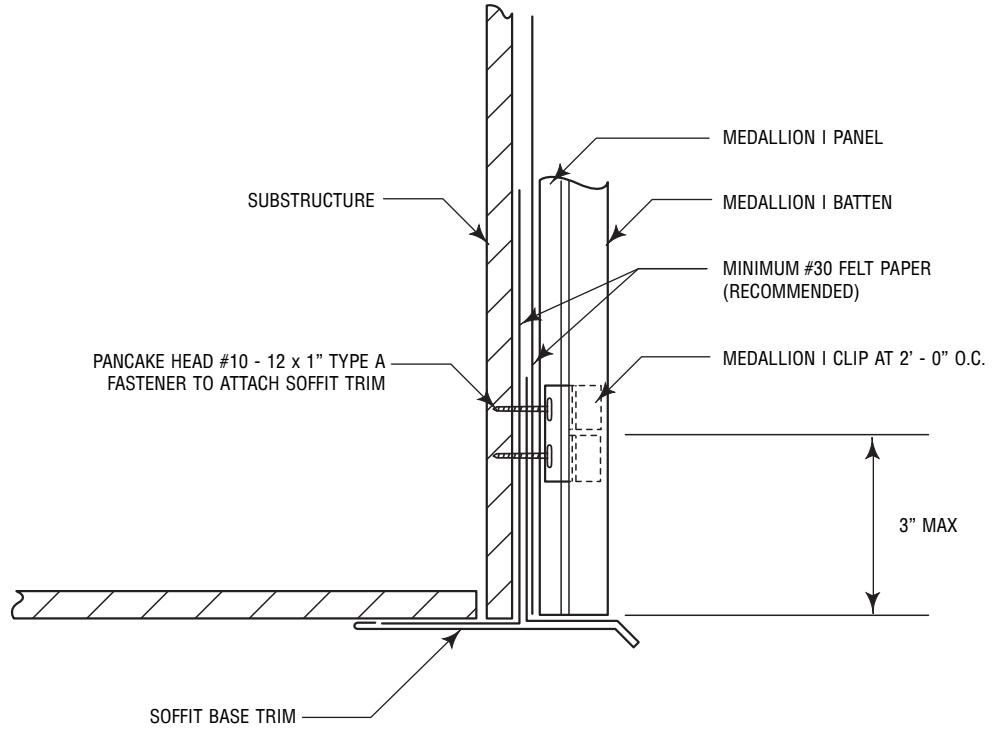

### NOTES:

1. Soffit base trim should be installed with the clip fasteners.
2. If necessary to cut wall panels, cut the end that will be used on the top.
3. Fasteners for attachment to soffit are not by McElroy Metal.



# ◆ ◆ ◆ ◆ Medallion I ◆ ◆ ◆ ◆

## OUTSIDE CORNER

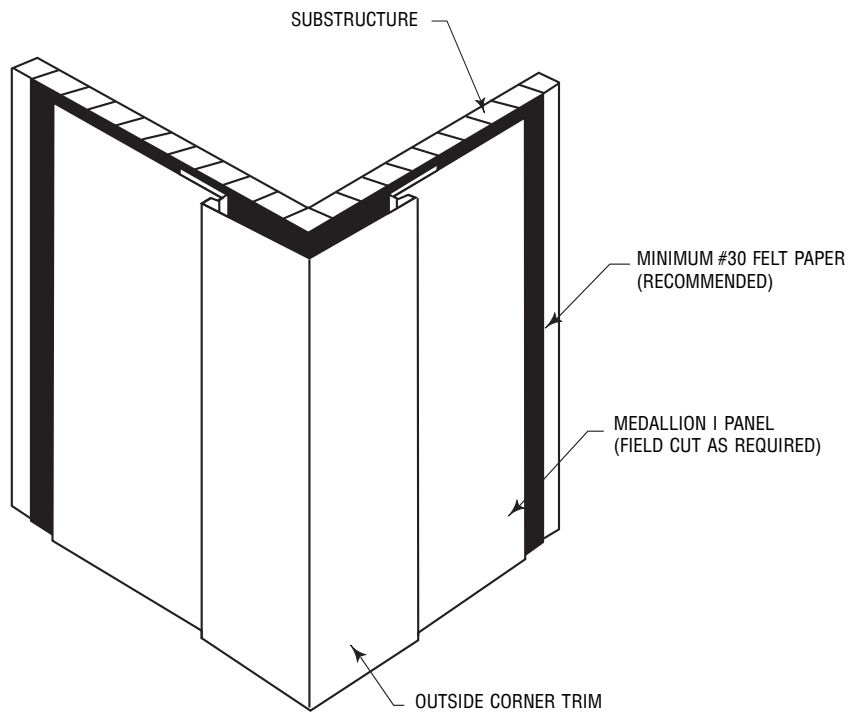
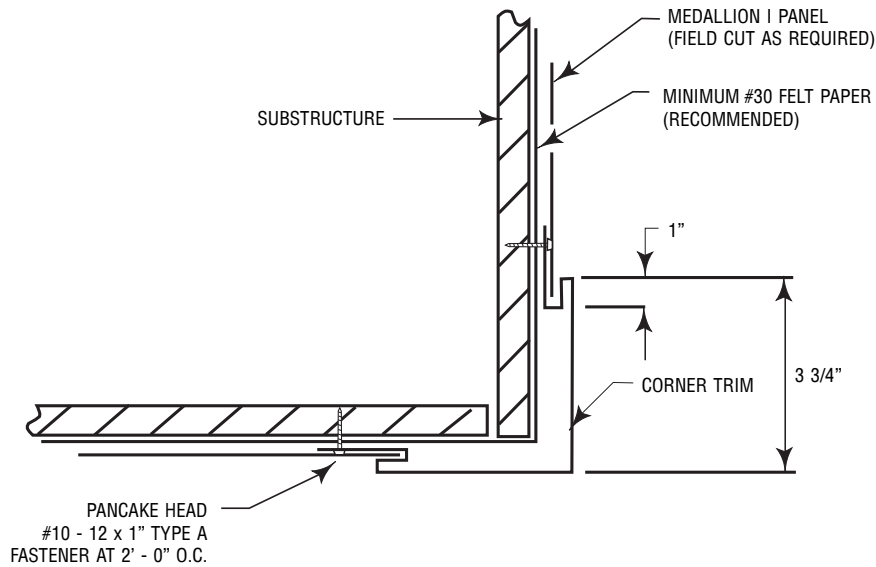

### NOTES:

1. Attach corner trim with fasteners on 2'-0" O.C.
2. Field cut panels as shown to fit into corner trim.



# ◆ ◆ ◆ ◆ Medallion I ◆ ◆ ◆ ◆

## INSIDE CORNER

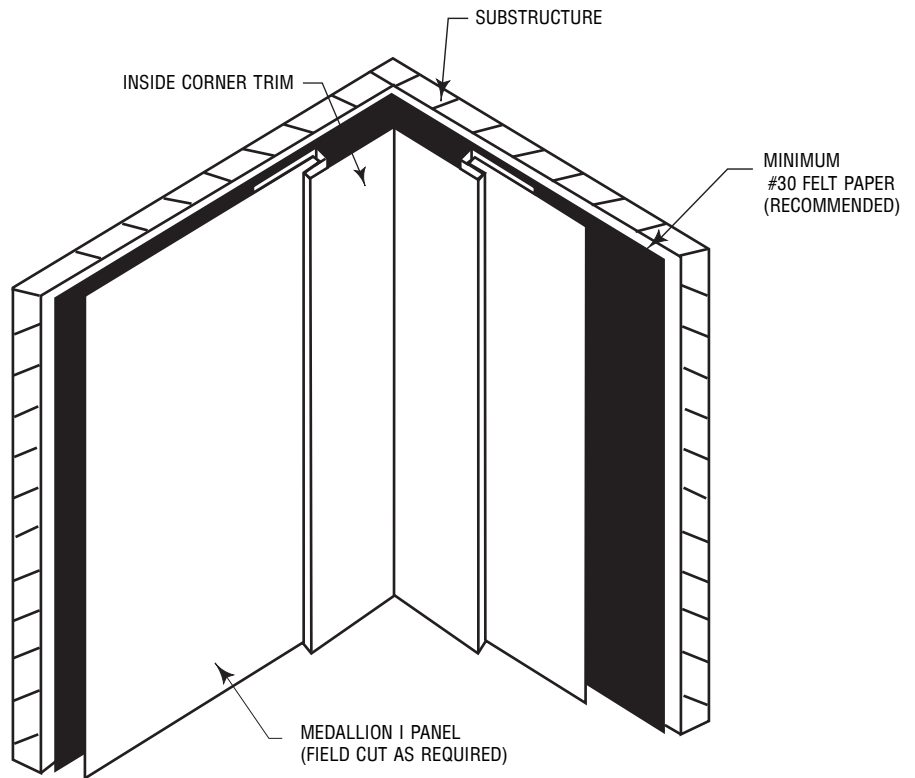
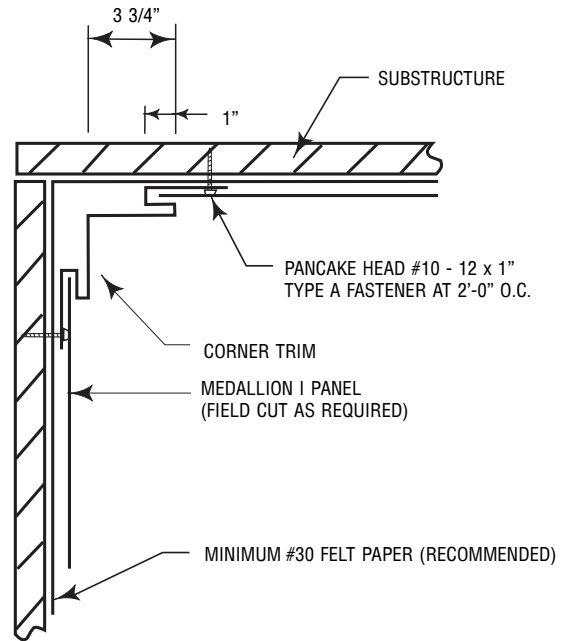

### NOTES:

1. Attach corner trim with fasteners on 2'-0" centers.
2. Field cut panels, as shown, to fit into corner trim.



# ◆ ◆ ◆ ◆ Medallion I ◆ ◆ ◆ ◆

## EAVE WITH OFFSET CLEAT

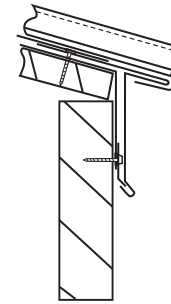
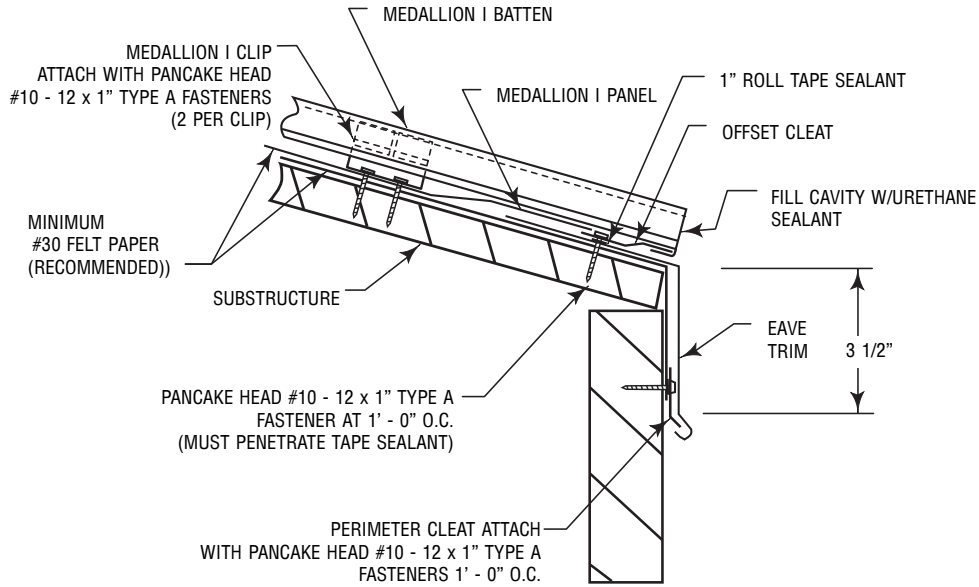

EAVE DRIP TRIM

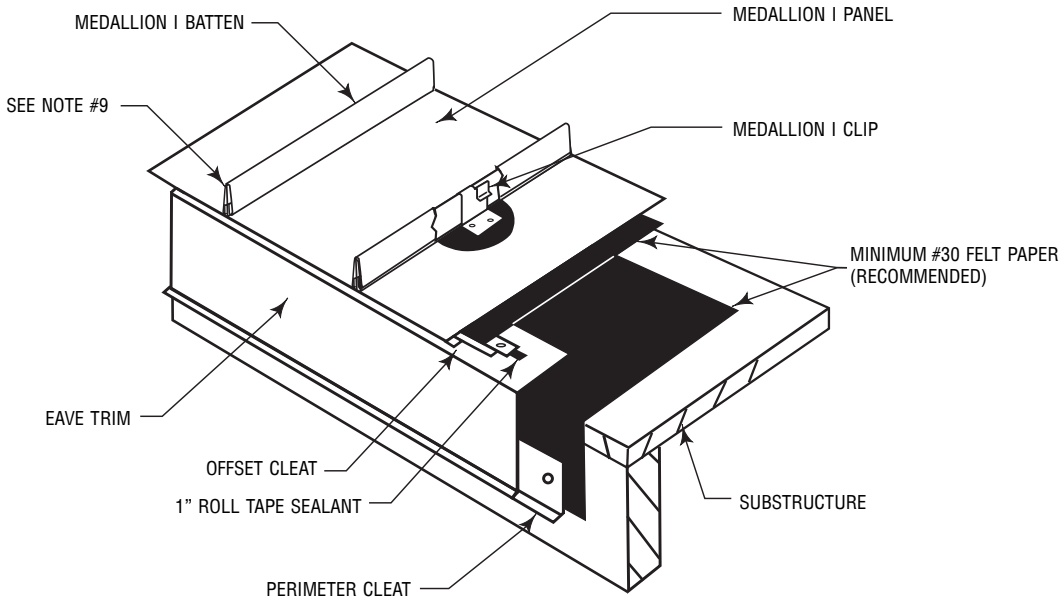

### NOTES:

1. Attach perimeter cleat as shown.
2. Secure eave trim to perimeter cleat.
3. Apply a continuous run of 1" roll tape sealant on eave trim.
4. Locate offset cleat over tape sealant and fasten to substructure.  
Pancake head fasteners must penetrate the sealant.
5. Field cut legs of the panel back 1 1/2".
6. Use panel hemming tool to form open hem with pan of panel.
7. Engage open hem to offset cleat while allowing clearance for thermal movement.
8. Locate a clip approximately 6" up from transition.
9. See batten detail for closing off eave.





# ◆ ◆ ◆ ◆ Medallion I ◆ ◆ ◆ ◆

## EAVE WITH STANDARD GUTTER AND OFFSET CLEAT

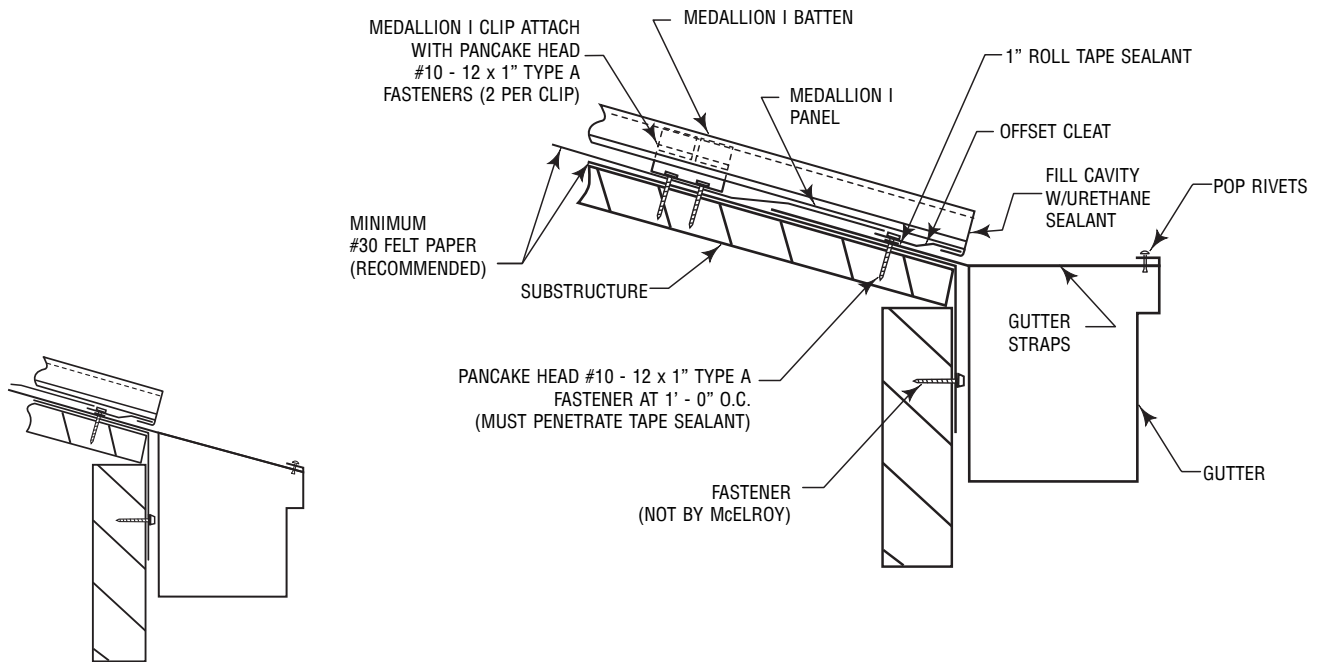

SUGGESTED FOR HIGH SNOW AREAS

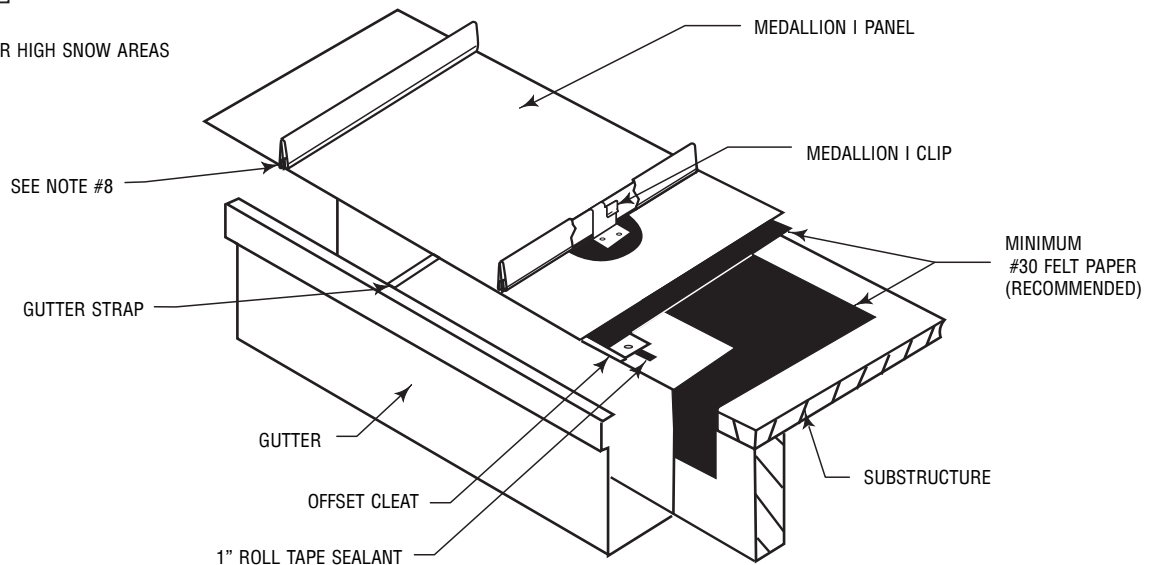

### NOTES:

1. Field notch 1 1/2" off leg of panel using panel hemming tool to form open hem with pan of panel.
2. Locate gutter and place a continuous run of 1" roll tape sealant on gutter leg.
3. Locate a gutter strap at 2'-0" O.C. Place tape sealant on strap.
4. Locate offset cleat trim and fasten through cleat, strap, sealant, gutter and into the substructure.
5. Install panel while allowing clearance for thermal movement. Batten should extend to the end of the panel.
6. Field bend gutter strap and attach to gutter with two (2) pop rivets.
7. In areas of heavy snow or ice accumulation, see alternate gutter detail.
8. See batten detail for closing the eave.
9. Fasteners for attachment to wall substructure are not by McElroy Metal.
10. Snow guards should be used to prevent damage to gutter from sliding snow.



# ◆ ◆ ◆ ◆ Medallion I ◆ ◆ ◆ ◆

## EAVE TO WALL TRANSITION

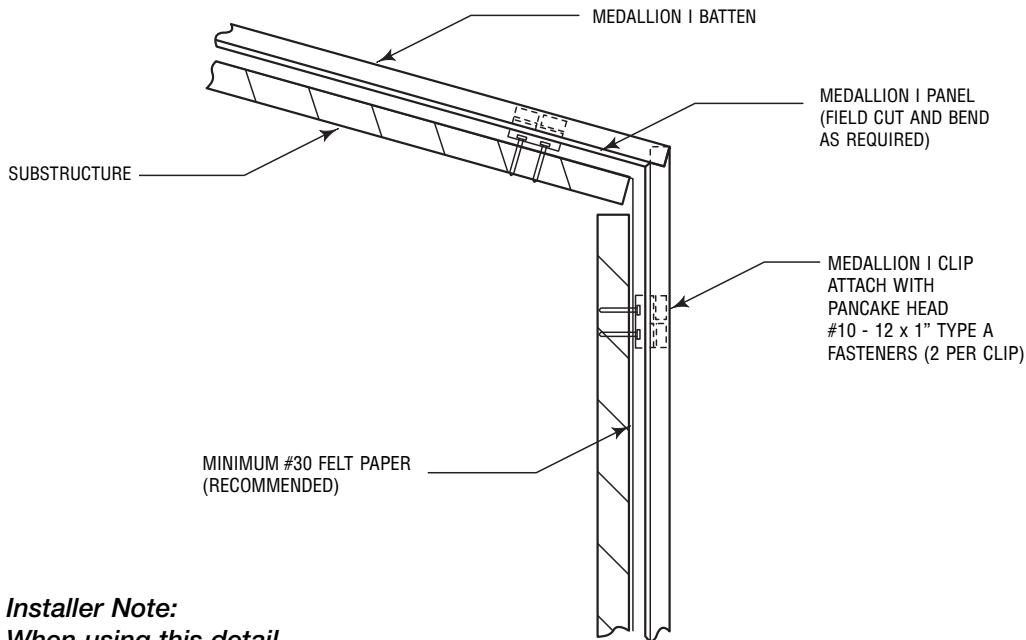

**Installer Note:**  
When using this detail, ridge or high side must float.

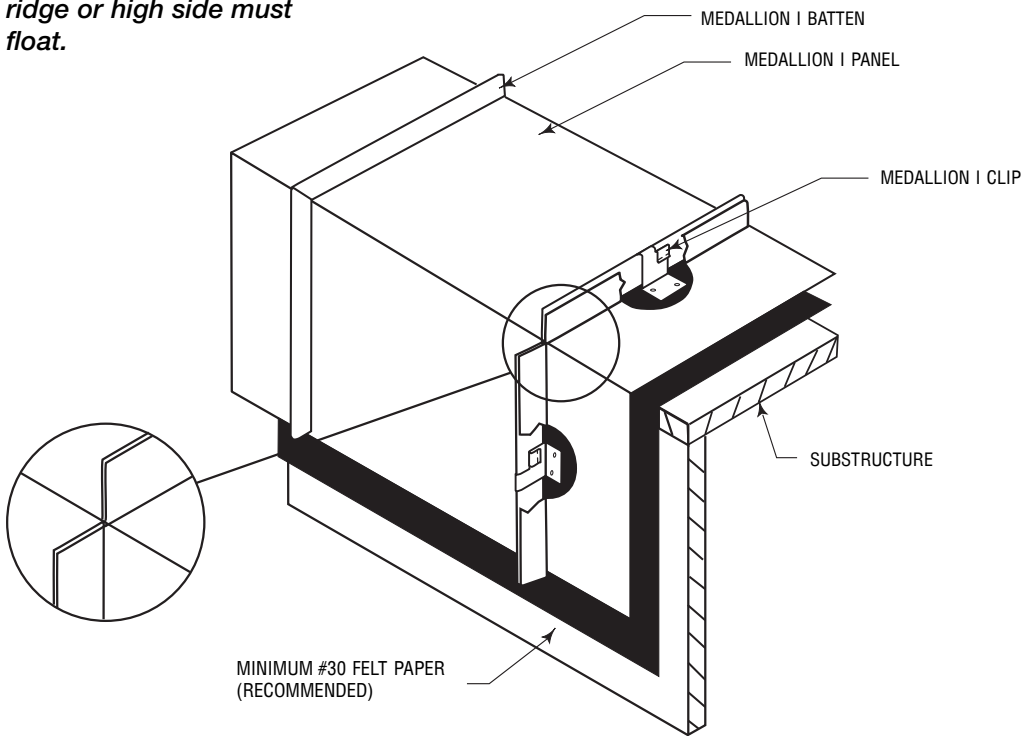

### NOTES:

1. Locate a clip approximately 6" up from transition.
2. Field cut leg of panel and field bend to required transition angle.
3. Locate a clip approximately 6" down from transition and attach panel.
4. Apply tube sealant at the panel transition before installing batten.
5. Add 2" to batten length. Field notch and field bend to fit panel. Apply tube sealant and pop rivet batten if required.
6. Snow guards should be used to prevent damage to this detail from sliding snow.



# Medallion I

## RAKE STARTING ON MODULE W/O WALL PANEL

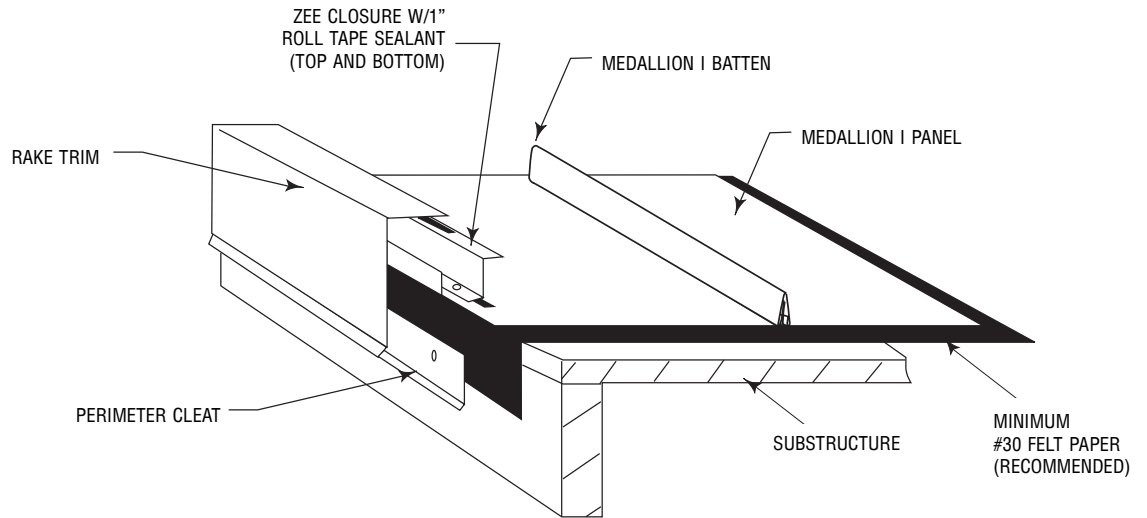
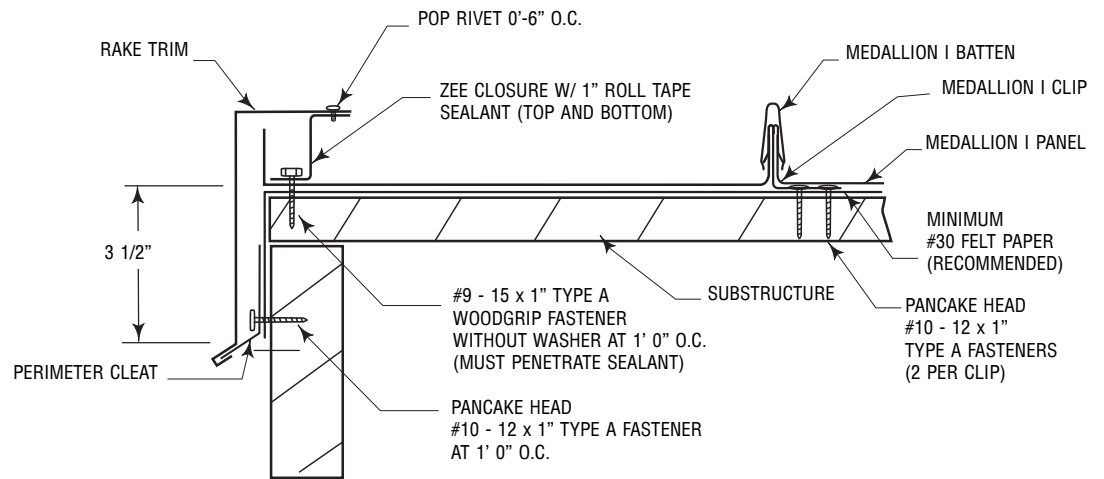

### NOTES:

1. Apply a continuous run of 1" roll tape sealant under zee closure before fastening.
2. Attach zee closure with fasteners on 1'-0" centers.
3. Apply a continuous run of 1" roll tape sealant over zee closure before fastening rake trim.
4. Fasten perimeter cleat per dimension shown (following roof slope) and then attach rake trim.

# ◆ ◆ ◆ ◆ Medallion I ◆ ◆ ◆ ◆

## RAKE TERMINATING OFF MODULE W/O WALL PANEL

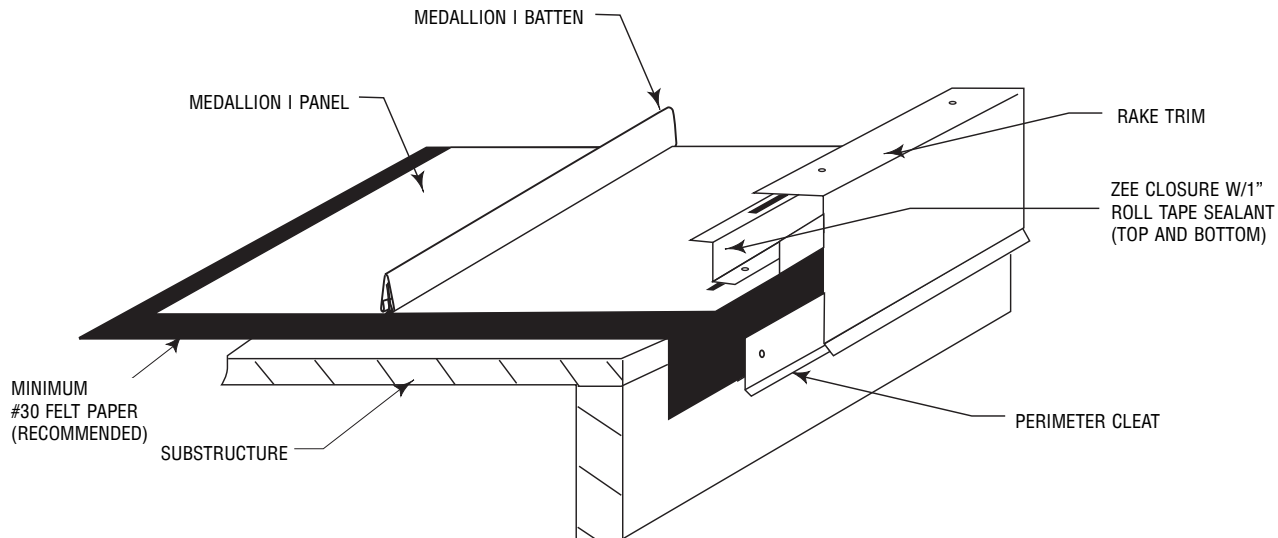
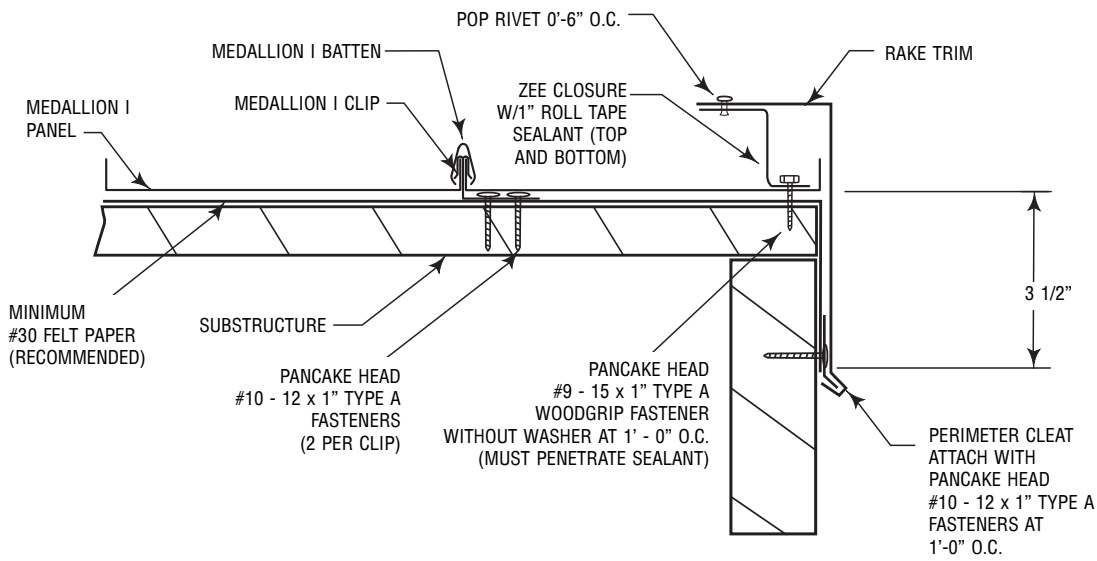

### NOTES:

1. Field cut Medallion panel as required.
2. Apply a continuous run of 1" roll tape sealant under zee closure before fastening.
3. Attach zee closure with fasteners on 1'-0" centers.
4. Apply a continuous run of 1" roll tape sealant over zee closure before fastening rake trim.
5. Fasten perimeter cleat per dimension shown following roof slope, and then attach rake trim.



# ◆ ◆ ◆ ◆ Medallion I ◆ ◆ ◆ ◆

## RAKE STARTING ON MODULE W/WALL PANEL

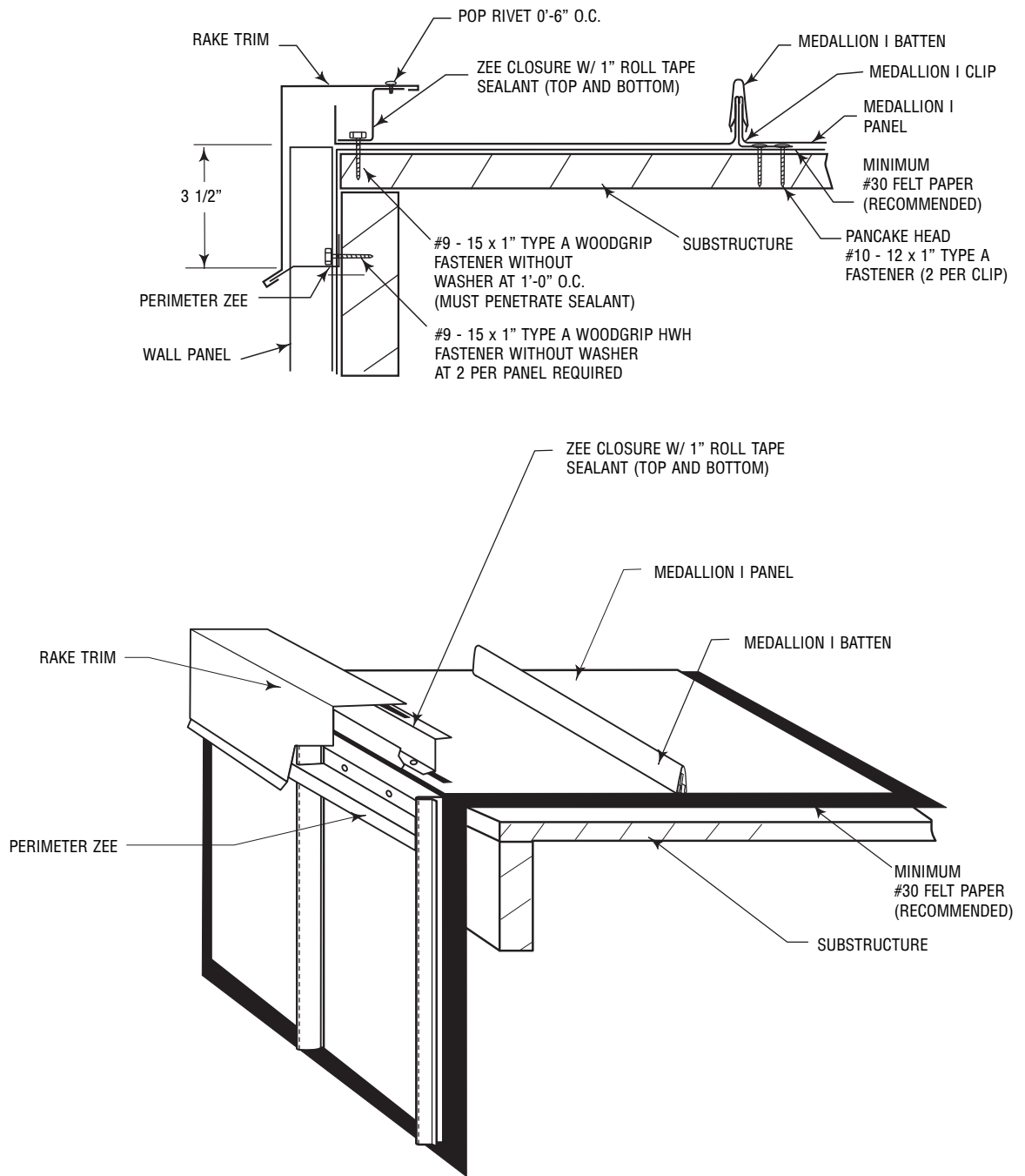

### NOTES:

1. Start Medallion panel on the wood or steel-line as shown.
2. Apply a continuous run of 1" roll tape sealant under zee closure before fastening.
3. Attach zee closure with fasteners on 1'-0" centers.
4. Apply a continuous run of 1" roll tape sealant over zee closure before fastening rake trim.
5. Fasten perimeter zee per dimension shown (following roof slope) and then attach rake trim.



# ◆ ◆ ◆ ◆ Medallion I ◆ ◆ ◆ ◆

## START RAKE

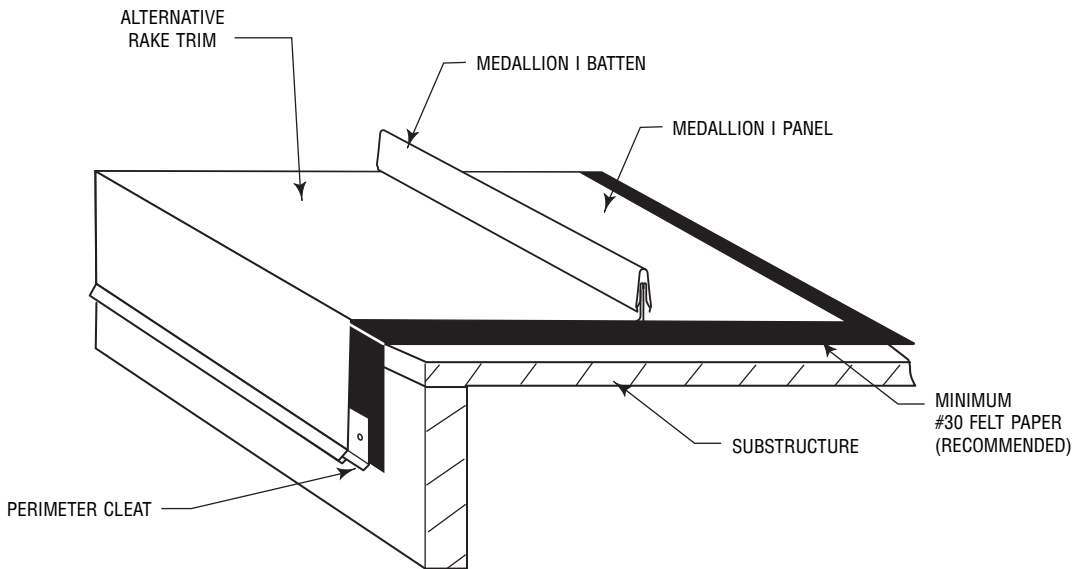
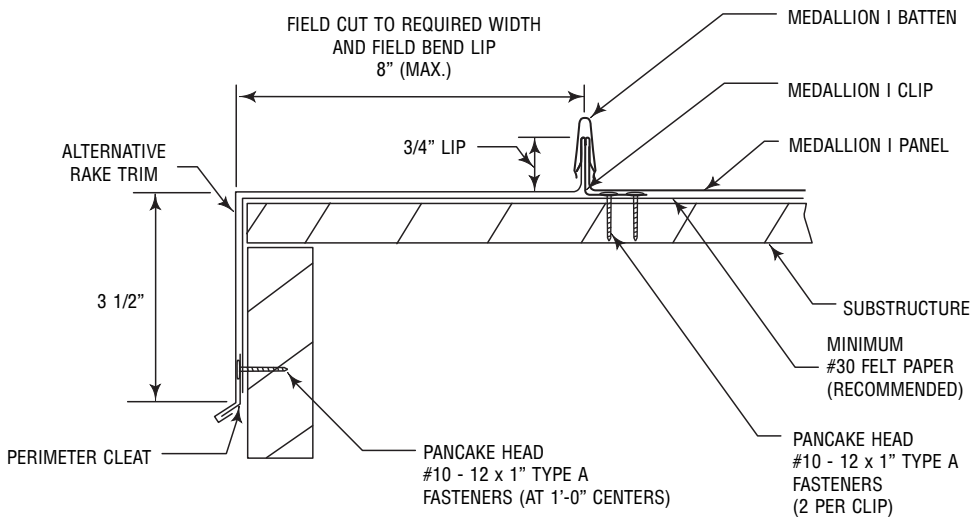

### NOTES:

1. Fasten perimeter cleat per dimension shown, following roof slope.
2. Field cut rake trim to required width (8" max.).
3. Field bend 3/4" high lip on rake trim.
4. Install Medallion I clips, at 2'-0" (max), O.C.



# ◆ ◆ ◆ ◆ Medallion I ◆ ◆ ◆ ◆

## FINISH RAKE

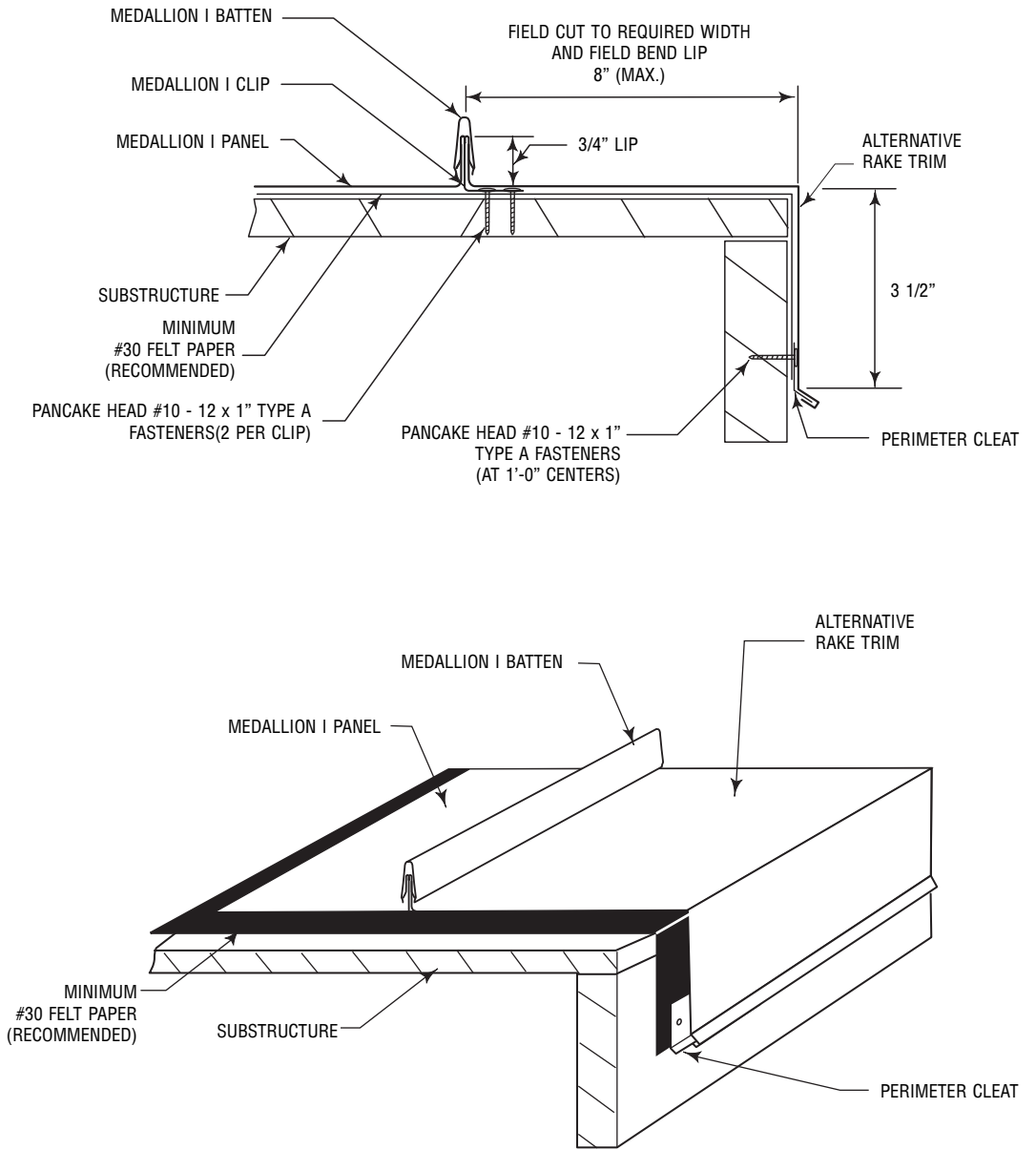

### NOTES:

1. Fasten perimeter cleat per dimension shown, following roof slope.
2. Field cut rake trim to required width (8" max.).
3. Field bend 3/4" high lip on rake trim.



# ◆ ◆ ◆ ◆ Medallion I ◆ ◆ ◆ ◆

## RIDGE/HIP

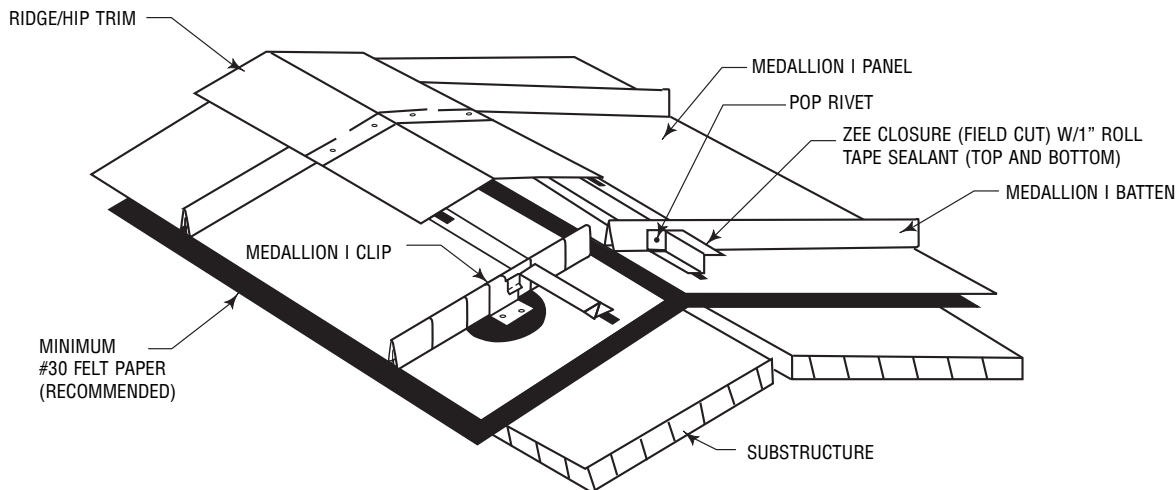
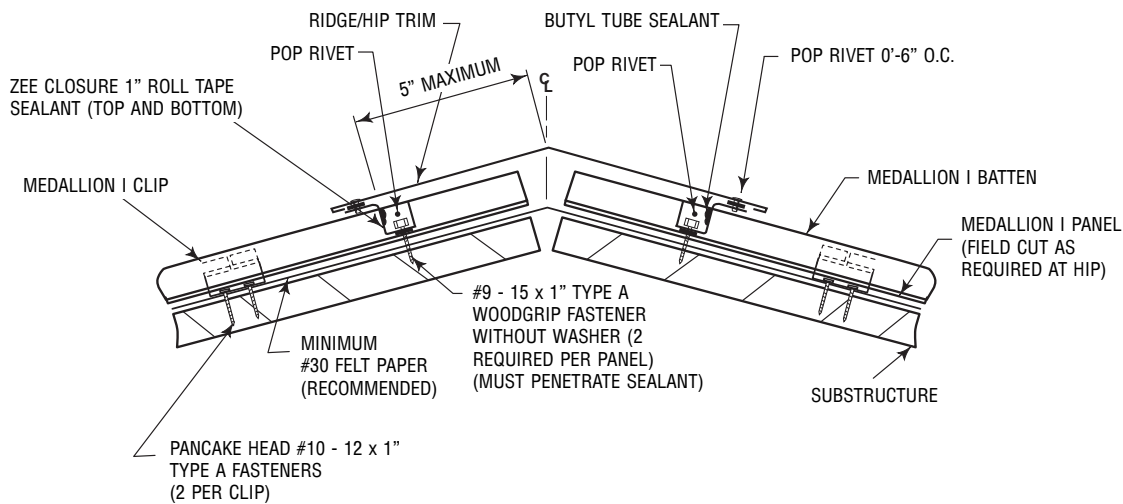

### NOTES:

1. Install panels with a clip approximately 1'-0" downhill on each side of the ridge or hip.
2. Install batten to edge of panel.
3. Apply a run of 1" roll tape sealant between panel legs about 5" maximum down from centerline of ridge.
4. Field cut and attach zee closure with two (2) fasteners through closure, sealant, panel and into substructure. Pop rivet to batten as shown.
5. Apply tube sealant to zee closure and batten connection.
6. Apply a continuous run of 1" roll tape sealant to top of zee closure.
7. Attach ridge/hip trim to zee closure with a pop rivet on 6" centers.
8. Lap ridge/hip trim with 1" roll tape sealant and pop rivets. Lap away from the prevailing wind direction.





# ◆ ◆ ◆ ◆ Medallion I ◆ ◆ ◆ ◆

## HI-SIDE CONDITION WITH WALL PANEL

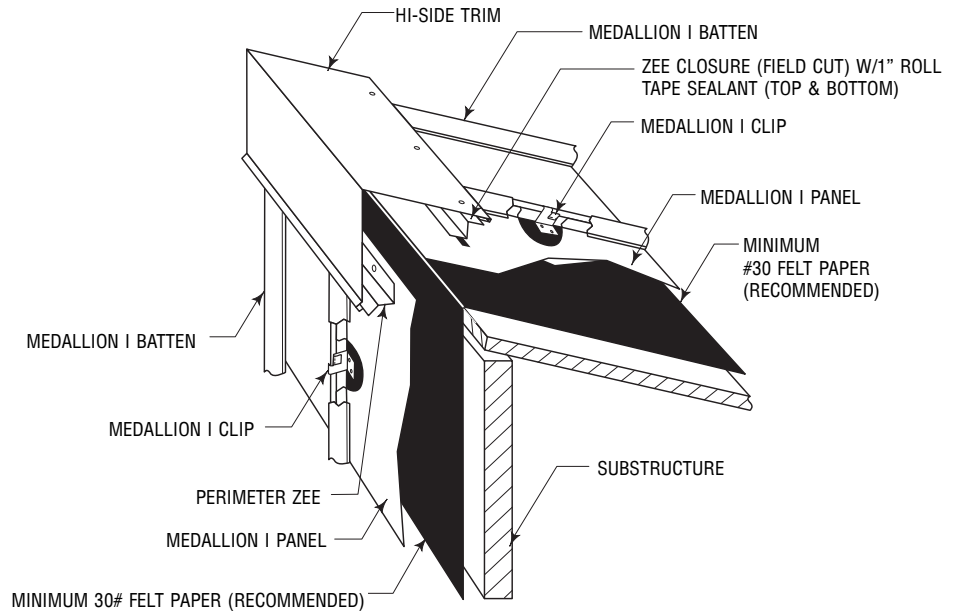
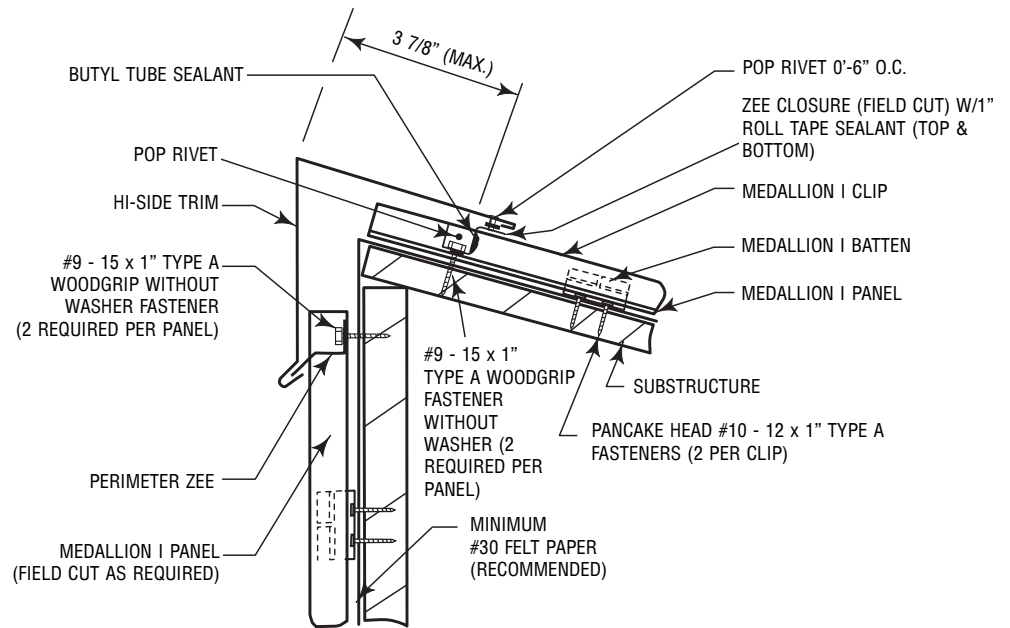

### NOTES:

1. Install panels with a clip approximately 1'-0" downhill.
2. Install batten to edge of panel.
3. Apply a run of 1" tape sealant between panel legs about 3 7/8" maximum downhill.
4. Field cut and attach zee closure with two (2) fasteners per panel. Pop rivet to batten as shown
5. Apply tube sealant to zee closure and batten connection.
6. Apply a continuous run of 1" roll tape to top of ZEE closure.
7. Attach perimeter zee as shown.
8. Slide high side trim over perimeter zee before attaching to ZEE closure.
9. Lap high side trim with 1" roll tape and pop rivets.



# ◆ ◆ ◆ ◆ Medallion I ◆ ◆ ◆ ◆

## HI-SIDE CONDITION WITHOUT WALL PANEL

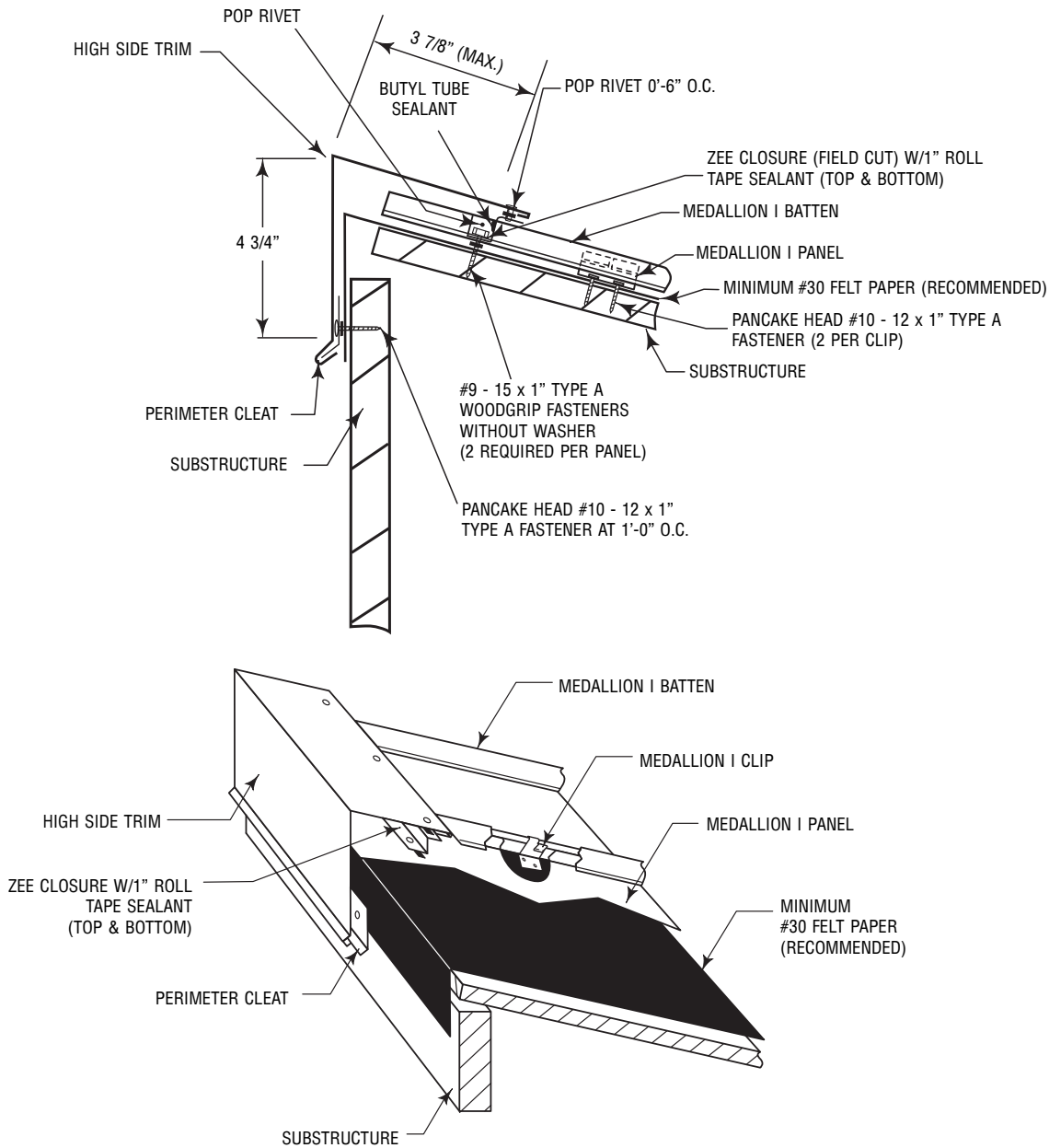

### NOTES:

1. Install panels with a clip approximately 1'-0" downhill.
2. Install batten to edge of panel.
3. Apply a run of 1" tape sealant between panel legs about 3 7/8" maximum downhill.
4. Field cut and attach zee closure with two (2) fasteners per panel. Pop rivet to batten as shown.
5. Apply tube sealant to zee closure and batten connection.
6. Apply a continuous run of 1" roll tape to top of ZEE closure.
7. Attach perimeter cleat as shown.
8. Slide high side trim over perimeter cleat before attaching to ZEE closure.
9. Lap high side trim with 1" roll tape and pop rivets.



# ◆ ◆ ◆ ◆ Medallion I ◆ ◆ ◆ ◆

## VALLEY

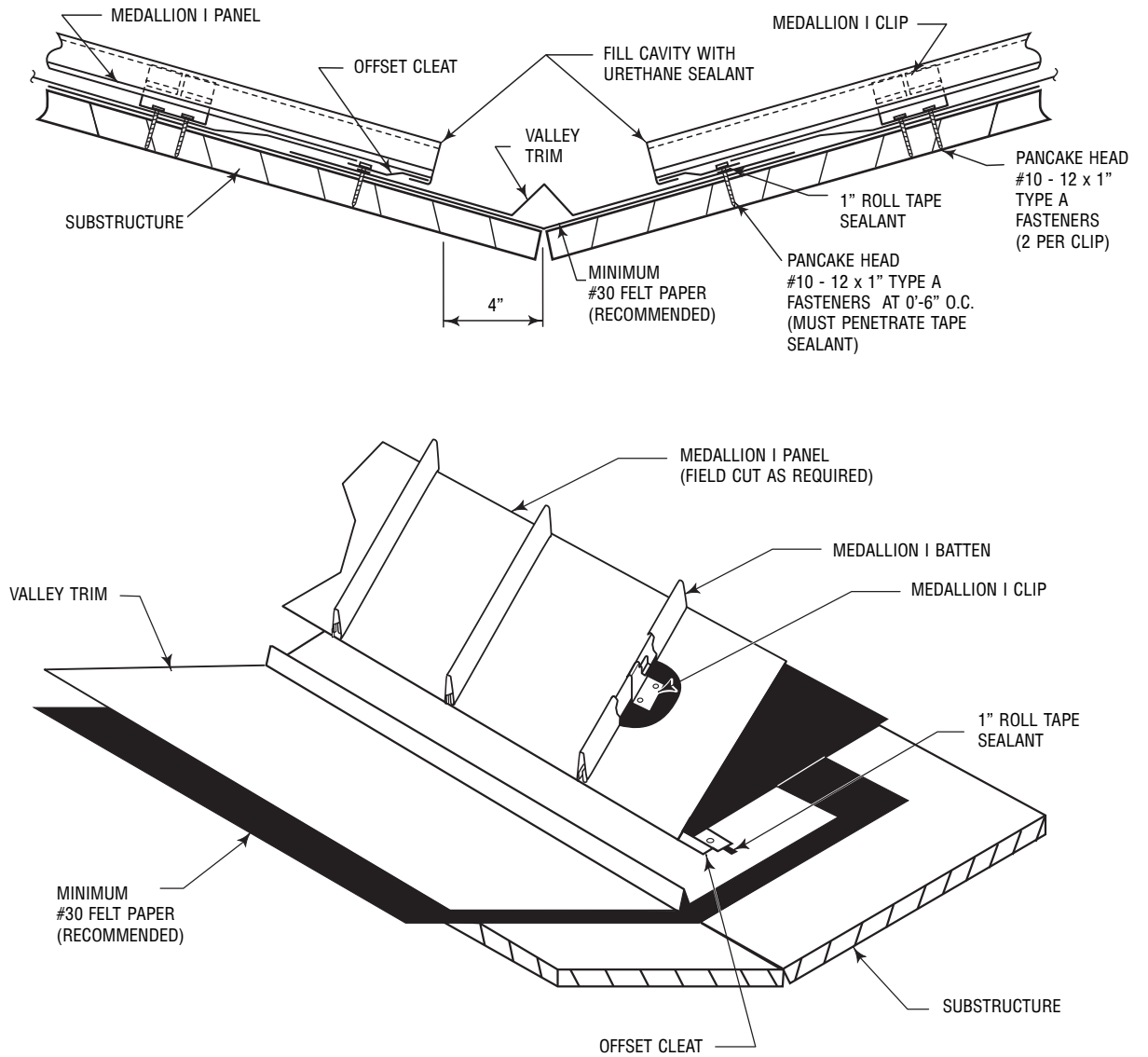

### NOTES:

1. Locate valley trim over substructure.
2. Apply a continuous run of 1" roll tape sealant over valley trim and under offset cleat.
3. Locate offset cleat approximately 4" from center of valley trim and fasten through offset cleat, sealant, valley trim and into substructure.
4. Field cut legs of the panel back 1 1/2".
5. Use panel hemming tool to form open hem with pan of panel.
6. Engage open hem to offset cleat, allow clearance for thermal movement.
7. Locate a clip 6" from offset cleat.



# ◆ ◆ ◆ ◆ Medallion I ◆ ◆ ◆ ◆

## PANEL END LAP

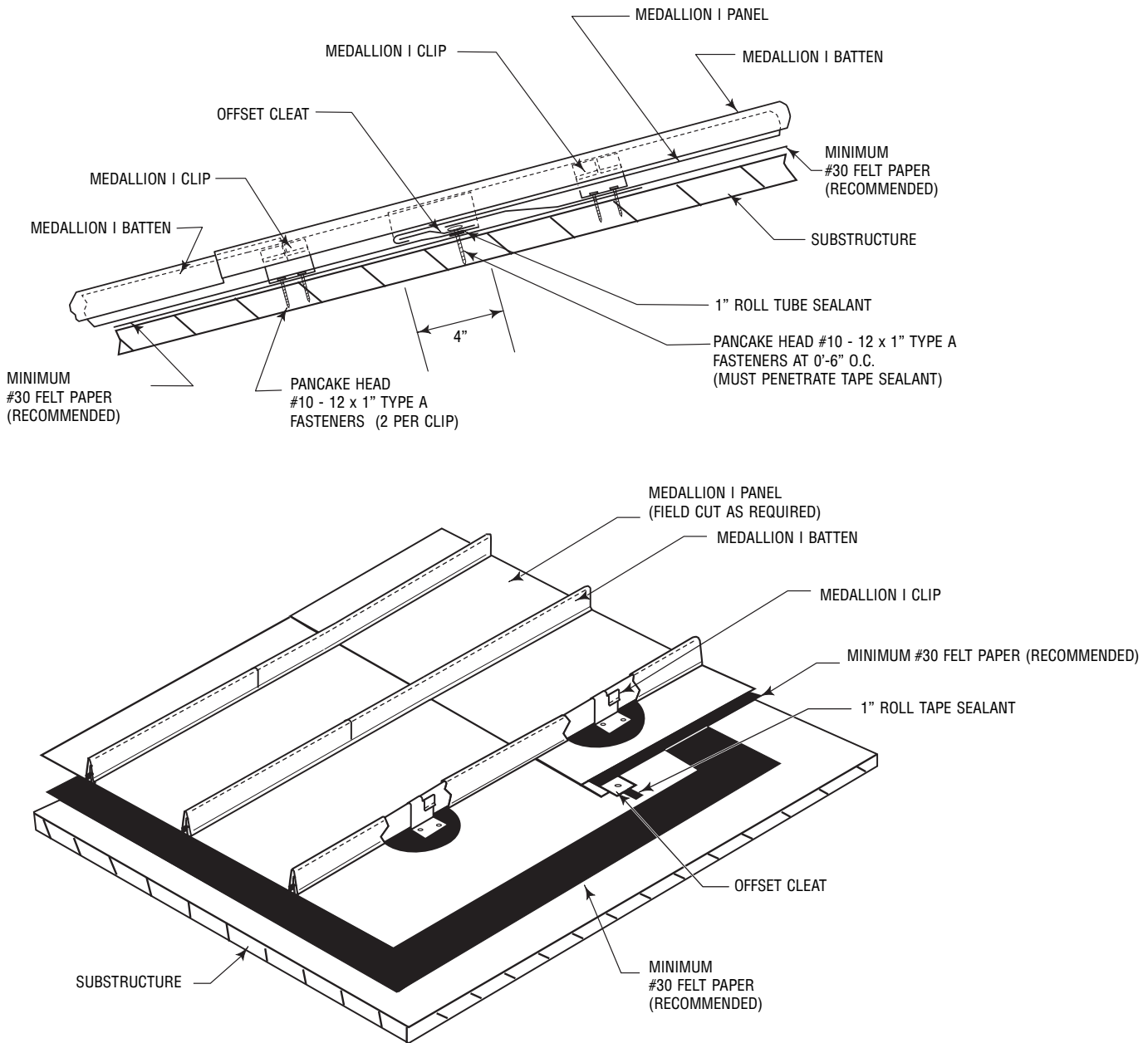

### NOTES:

1. Attach lower roof panel with a clip approximately 8" from end of panel.
2. Apply a continuous run of 1" tube sealant between panel legs, about 12" long.
3. Locate offset cleat trim approximately 4" from the edge of the lower roof panel. Field cut to fit between panel legs.
4. Fasten through offset cleat, lower panel, sealant and into the substructure.
5. Field notch 1 1/2" off leg of panel, hem and slide into offset cleat. Allow clearance for thermal movement. Be sure a clip is installed approximately 8" from end of the upper roof panel.
6. A batten lap should not occur at a panel lap.



# ◆ ◆ ◆ ◆ Medallion I ◆ ◆ ◆ ◆

## RAKE STARTING ENDWALL PARAPET ON MODULE

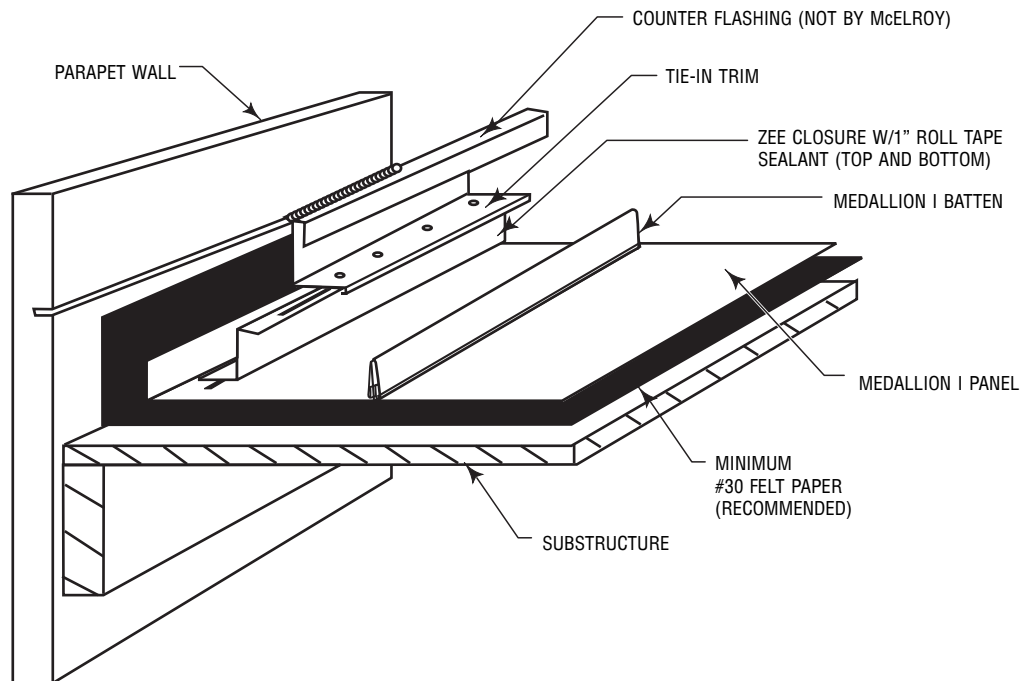
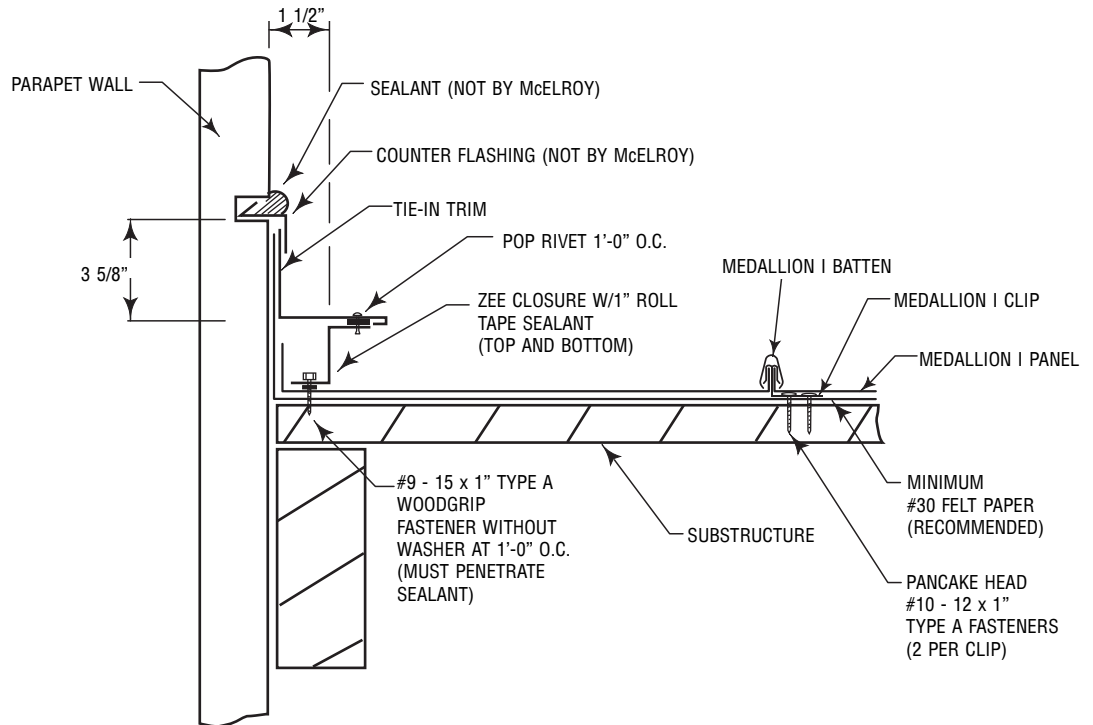

### NOTES:

1. Apply a continuous run of 1" roll tape sealant on panel approximately 1 1/2" in from edge of substructure.
2. Locate zee closure over tape sealant and attach with fasteners on 1'-0" centers.
3. Apply a continuous run of 1" roll tape sealant over zee closure.
4. Fasten tie-in trim to zee closure with pop rivets on 1'-0" centers.
5. Counter flashing and sealant is not by McElroy Metal.



# ◆ ◆ ◆ ◆ Medallion I ◆ ◆ ◆ ◆

## RAKE FINISH ENDWALL PARAPET WITH WALL PANELS

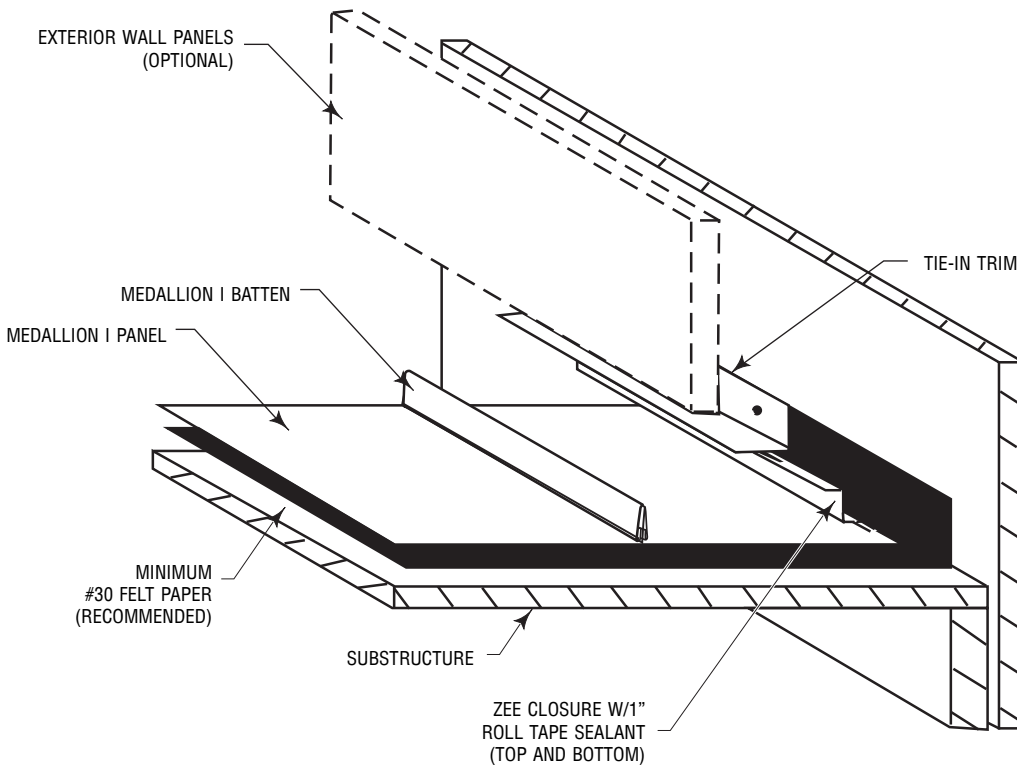
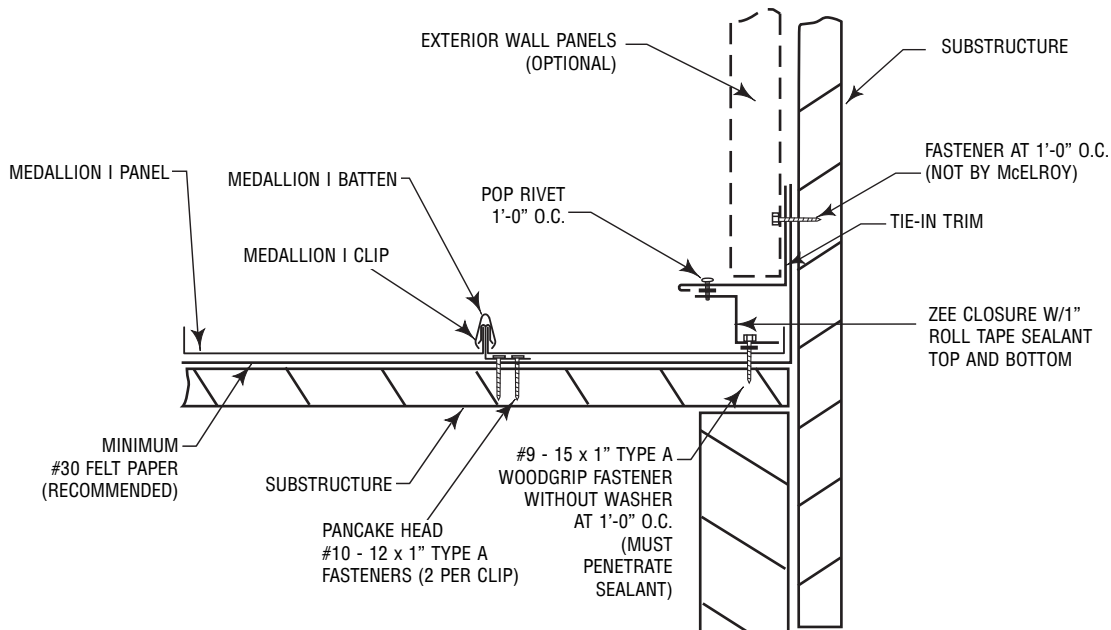

### NOTES:

1. After panels are installed, field cut panel at wall if required.
2. Apply a continuous run of 1" roll tape sealant on panel approximately 1 1/2" in from edge of substructure.
3. Locate zee closure over tape sealant and attach with fasteners on 1'-0" centers.
4. Apply a continuous run of 1" roll tape sealant over zee closure.
5. Fasten tie-in trim to zee closure with pop rivets on 1'-0" centers.



# ◆ ◆ ◆ ◆ Medallion I ◆ ◆ ◆ ◆

## HIGH SIDE TIE-IN SIDEWALL PARAPET WITH WALL PANELS

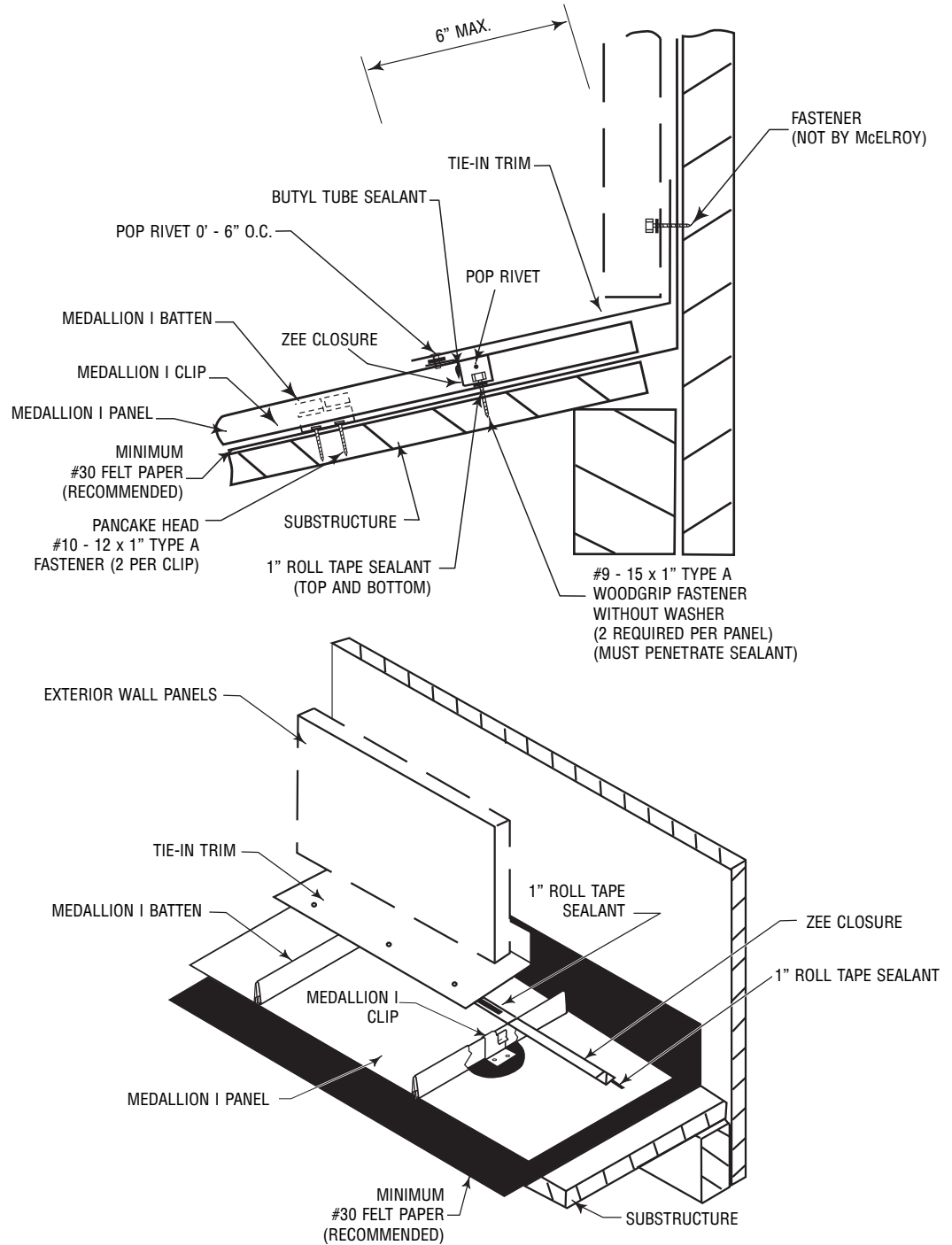

### NOTES:

1. After panels and battens are installed, place a continuous run of 1" roll tape sealant approximately 6" from edge of wall substructure.
2. Field cut zee closure and install over tape sealant and attach with two (2) fasteners through closure, sealant, panel, and into substructure. Locate as shown. Pop rivet to batten as shown.
3. Apply a continuous run of 1" roll tape sealant over zee closure and fasten trim to closure with pop rivet on 6" centers. Apply tube sealant at closure to batten.
4. Fasteners for attachment to wall substructure are not by McElroy Metal.



# ◆ ◆ ◆ ◆ Medallion I ◆ ◆ ◆ ◆

## HIGH SIDE TIE-IN SIDEWALL PARAPET ABOVE ROOFLINE

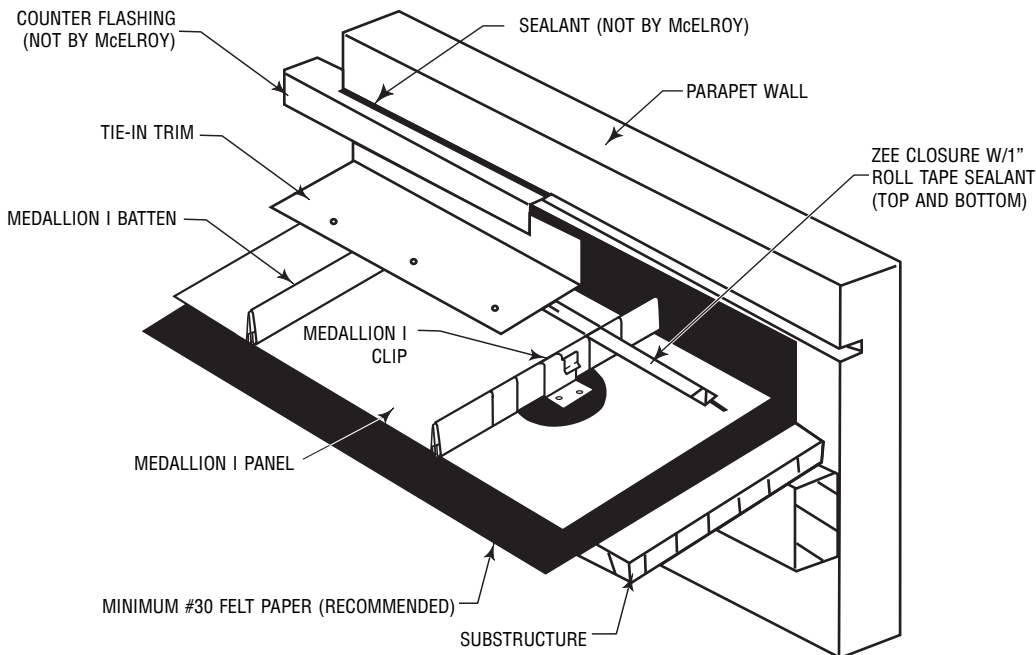
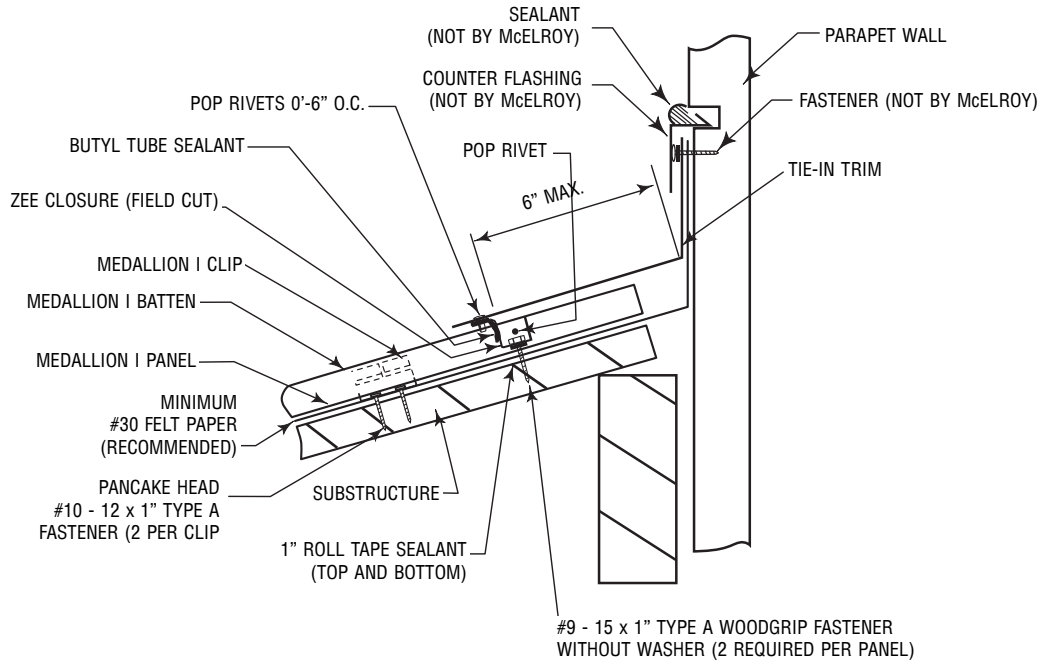

### NOTES:

1. After panels and battens are installed, place a continuous run of 1" roll tape sealant approximately 6" from edge of wall substructure.
2. Field cut zee closure and install over tape sealant and attach with two (2) fasteners through closure, sealant, panel and into substructure. Locate as shown. Pop rivet to batten as shown.
3. Apply a continuous run of 1" roll tape sealant over zee closure and fasten trim to closure with pop rivets on 6" centers. Use tube sealant at closure to batten.
4. Fasteners for attachment to parapet wall is not by McElroy Metal.
5. Counter flashing and sealant to parapet wall are not by McElroy Metal.



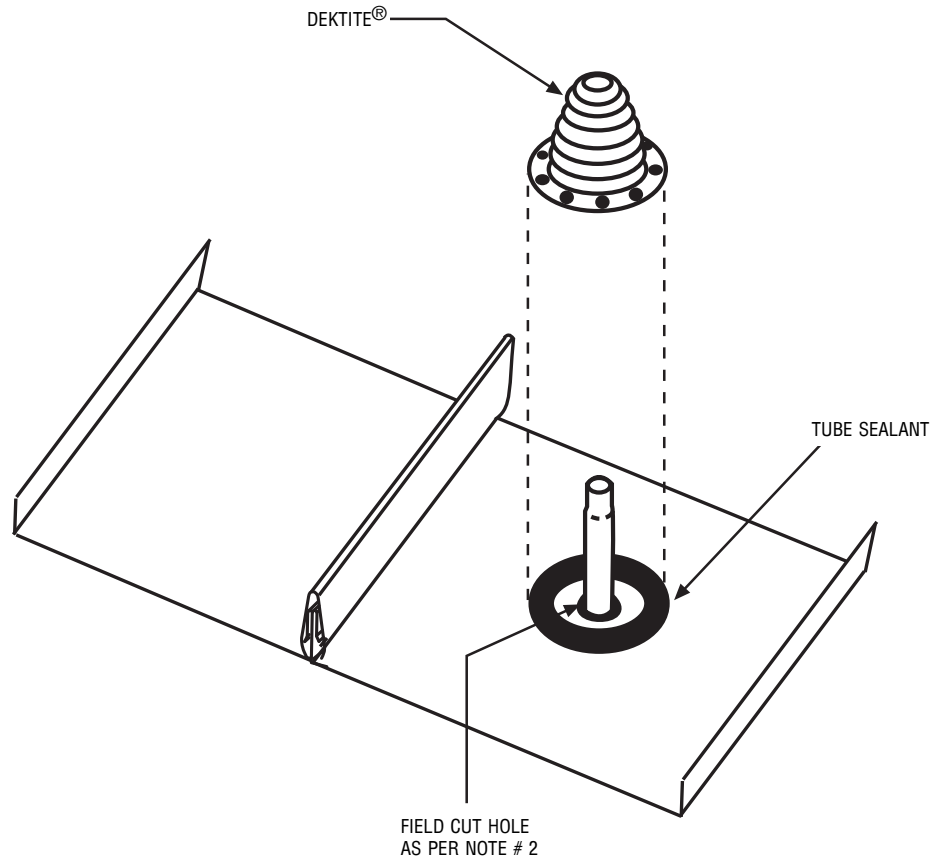

**ROOF JACK INSTALLATION****NOTES:**

1. Before cutting hole in sheet, consider the best position to suit size of Dektite® selected.
2. Cut a neat hole with minimum clearance for pipe and install pipe.
3. Rubber sleeve should be a watertight fit on pipe. If rubber has to be cut, a neat hole 1/2" dia. less than outside pipe diameter should be cut in Dektite®. Use a sharp pair of scissors and avoid nicks.
4. Apply tube sealant to underside of base and, using water as lubricant, slide flashing along until it meets sheet.
5. Hand press Dektite® base on to sheet, pressing base firmly to sheet to avoid gaps, progressively drill and fasten to sheet. Fasten to panel with #14 x 7/8" laptek® Fasteners.



◆ ◆ ◆ ◆ **Medallion I** ◆ ◆ ◆ ◆

**NOTES**





★ MANUFACTURING LOCATIONS ● SERVICE CENTERS  
 ★ MANUFACTURING AND SERVICE CENTER



For more information:  
**800-562-3576**  
[www.mcelroymetal.com](http://www.mcelroymetal.com)

**CORPORATE OFFICE**  
 1500 HAMILTON RD.  
 BOSSIER CITY, LA 71111  
 Ph: (800) 562-3576  
 Fax: (318) 747-8029

**MANUFACTURING LOCATIONS**

<b>BOSSIER CITY, LA</b>	<b>CLINTON, IL</b>	<b>MARSHALL, MI</b>	<b>MERKEL, TX</b>
<b>WINCHESTER, VA</b>	<b>ADELANTO, CA</b>	<b>PEACHTREE CITY, GA</b>	<b>MAUSTON, WI</b>
<b>LEWISPORT, KY</b>	<b>ASHBURN, GA</b>	<b>SUNNYVALE, TX</b>	

**McELROY METAL**  
**SERVICE**  
 CENTER

5215 Leo St. <b>Alexandria, LA 71301</b>	1500 Hamilton Rd. <b>Bossier City, LA 71111</b>	3052 Yadkin <b>Chesapeake, VA 23323</b>	10460 Revere Rd. <b>Clinton, IL 61727</b>
3215 Highway 59 <b>Diamond, MO 64840</b>	409 Lovejoy Road <b>Ft. Walton Beach, FL 32548</b>	14373 Creosote Rd., Bld. B <b>Gulfport, MS 39503</b>	10504 E. 59th Street <b>Indianapolis, IN 46236</b>
9435 U.S. Hwy 60 W. <b>Lewisport, KY 42351</b>	3036 Progress Road <b>Madison, WI 53716</b>	2506 Midpark Dr. <b>Montgomery, AL 36109</b>	8304 Hwy. 70 E. <b>North Little Rock, AR 72117</b>
613 North Bierdeman Rd. <b>Pearl, MS 39208</b>	5300 83rd Street <b>Sacramento, CA 95826</b>	1365 Dean Forest Rd. <b>Savannah, GA 31405</b>	
165 North Outer Road West <b>Valley Park, MO 63088</b>	1144 Silstar Rd. <b>West Columbia, SC 29170</b>	30000 US Hwy. 69 <b>Winston, MO 64689</b>	

**Website: [www.mcelroymetal.com](http://www.mcelroymetal.com) · E-mail: [info@mcelroymetal.com](mailto:info@mcelroymetal.com)**