



Technical Bulletin

Issue Date: September 9, 2002

Revised: August 12, 2024

No. 03-153-02

UL Construction #506B

Maxima, Maxima ADV

UL 580 Class 90 wind Uplift

1. **Metal Roof Deck Panels*** - No. 24 MSG min coated steel. Max panel width 18 in.; min 12 in. Rib height 2 in. Panels continuous over three or more clips (Item 2). The panel flat area may have optional striated or minor ribs placed at various locations in the panel flat area beginning min of 2 in. from side ribs. The upper flange of the panel rib may be horizontal, or optionally formed down to produce an angle of 0 to 90° between the vertical segment and the top flange of the rib. Panel end lap 2 in. min. An end lap back-up plate (Item 2A) to be used at panel end lap. A bead of sealant may be used at panel end lap and side ribs. Ribs to be seamed with an electric or hand seaming tool to form a flange with a tight hem. Seaming process to include the upper portion of the panel clips (Item 2).
McElroy Metal Mill, Inc. "Maxima-212", "Maxima-216", "Maxima-218", "Maxima ADV"
- 1A. **Metal Roof Deck Panels*** - (Not shown) – Panels (coated steel only) may be physically or mechanically curved at a radius of 4 ft. or greater.
McElroy Metal Mill, Inc. "Maxima ADV"
2. **Roof Deck Fasteners* - (Panel Clips)** – Located at side of panels (Item 1) over substructure (Item 3, 3A, 3B or 3C with max spacing of 36 in. OC), or plywood decking (Item 7 with max spacing of 36 in. OC). Either of the following:
Fixed Clip (Not Shown) – One piece assembly fabricated from No. 22 MSG min thick steel, 3-1/2 in. wide.
McElroy Metal Mill, Inc. "Maxima Fixed Clip"
Floating Clip – Two piece assembly with a base fabricated from No. 16 MSG min thick steel, 2 in. wide and a tab fabricated from No. 22 MSG min thick steel, 4-1/4 in. wide.
McElroy Metal Mill, Inc. "Maxima Floating Clip"
- 2A. **End Lap Back-Up Plate** – (Not Shown) - No. 16 MSG min thick coated steel channel, 3 in. wide with two 3/8 in. deep legs. Max length 74 in. Located under the panel (Item 1) end lap (50 ksi min yield strength).
- 2B. **End Lap Back-Up-Plate** – (Optional) (Not Shown) - No. 16 MSG min thick coated steel. Width 11, 15 or 17 in., length 7 in. Two ¾ in. by ¾ in. tabs and a 1 in. deep vertical leg located at upslope edge of panel (50 ksi min yield strength).
- 2C. **Roof Deck Fasteners* (Cinch Plate) - (Optional) - (Not Shown)** – width 1-5/16 in. length 18 in. max. Fabricated from No. 20 MSG min thick stainless steel. Located over end lap.
3. **Substructure - (Gypsum Board)** – (Optional) – Min thick ½ in. To be placed on top of either the plywood decking (Item 7) or rigid insulation (Item 5). Combined thickness of the gypsum board and rigid insulation not to exceed 4 in. All joints to be taped with 2.5 in. wide joint tape.
- 3A. **Substructure - (Plywood)** – (Optional) - (Not Shown) - Plywood decking, used in lieu of gypsum board (Item 3), to be nom ½ in. thick, DOC PS-1 graded, exposure 1 sheathing, 40/20, CD. Located over rigid insulation (Item 5). Combined thickness of the plywood and rigid insulation (Item 5) not to exceed 10 in.
- 3B. **Substructure - (OSB)** – (Optional) - (Not Shown) - OSB decking, used in lieu of gypsum board (Item 3), to be nom ½" thick. Located over rigid insulation (Item 5). Combined thickness of the OSB and rigid insulation not to exceed 10 in.
- 3C. **Substructure - (Bearing Plate)** - (Optional) - (Not Shown) - Bearing plate to be used in lieu of gypsum board (Item 3) to be 4 by 4 in. by No. 18 MSG min thick coated steel (33 ksi min yield strength). Used under each clip (Item 2) over rigid insulation (Item 5) only when rigid insulation is located directly under panel (Item 1).
4. **Vapor Barrier** – (Optional) - Single ply, used between the substructure (Items 3, 3A or 3B) or plywood decking (Item 7) and panels (Item 1). To be min 30 lb roofing felt.
5. **Foamed Plastic - (Rigid Insulation) - (Optional)** – Max thickness 10 in. when gypsum board (Item 3), plywood (Item 3A) or OSB (Item 3B), or bearing plates (Item 3C) are used. Min bearing strength to be 20 psi. 1.8 pcf min density.
6. **Fasteners – (Screws)** – Fasteners used to attach panel clips (Item 2) to plywood substructure (Item 3A) or plywood/lumber decking (Item 7, 7A) to be No. 10-12 pancake head, No. 2 Phillips drive, A-point, coated steel screw, or No. 14-10 HHA plated steel self-tapping steel screw. Fastener length to penetrate plywood min ½ in. Two fasteners per clip. Fasteners (screws) used with Metal Roof Deck Panel designated Maxima ADV, Item 1, and Roof Deck Fasteners (panel clips) in Item 2 shall be 2 in. min. length. When used with curved panel, length to be min. 1 in.
- 6A. **Fasteners – (Screws)** – Fasteners used to attach panel clips (Item 2) through gypsum board, OSB or bearing plate (Item 3, 3B, or 3C, respectively) and foam plastic insulation (Item 5) into plywood/lumber deck (Item 7, 7A) to be No. 10-12 pancake head, No. 2 Phillips drive, A-point, steel screw or No. 12-13 No. 3 Phillips Drive coated steel truss head screw. Two screws used per clip. Fastener length to penetrate plywood deck min ½ in.
 Note: The panel clips may be fastened to the bearing plate using two No. 10-16 by 1 in. long self-driving, self-tapping, pancake head No. 2 Phillips drive coated steel screws. The panel clip/bearing plate combination is to be fastened to the plywood deck using two No. 12-13 No. 3 Phillips Drive coated steel truss head screws, inserted through a guide hole in the clip and bearing plate and into the plywood deck
- 6B. **Fasteners – (Screws)** – (Not Shown) - Fasteners used to attach plywood Substructure (Item 3A) through rigid insulation (Item 5) into plywood/lumber deck (Item 7, 7A) to be No. 14-13, No. 3 Phillips drive truss head screws. Fastener length to penetrate plywood deck min ½ in. Total of 33 fasteners per 4 by 8 ft plywood sheet to be used. Fasteners located in five rows along the 4 ft length in a 3-9-12-12-9-3 in. pattern. The two outer rows are in a 3-9-12-12-12-12-12-12-9-3 in. pattern and the three center rows are in a 3-21-24-24-21-3 in. pattern. All spacing from board edges.

MANUFACTURING LOCATIONS

ADELANTO, CA	ASHBURN, GA	BOSSIER CITY, LA	CLINTON, IL	DIAMOND, MO	HOUSTON, TX	LEWISPORT, KY
MARSHALL, MI	MAUSTON, WI	MERKEL, TX	PEACHTREE CITY, GA	SUNNYVALE, TX	WINCHESTER, VA	



- 6C. **Fasteners – (Screws) – (Not Shown)** - Fasteners used at end laps of panel (Item 1) to be one of the following: No. ¼ -14 by 1 in. long, Type AB point self-drilling, self-tapping, hex-washer-head, plated or stainless steel screws or No. 12-14 by 1-1/2 in. long self-drilling, self-tapping, hex-washer-head, plated steel screws. Spacing for 16 in. wide panels to be 1, 3, 4, 4, 3 in. pattern; spacing for 18 in. wide panels to be 1-1/2, 3-1/2, 4, 4, 3-1/2, 1-1/2 in. pattern.
7. **Plywood Deck** – Plywood decking to be graded per DOC PS-1 specifications, 19/32 in. thick, exposure 1, APA rated sheathing, 40/20 in. OC, square edged. Butt ends not blocked.
- 7A. **Substructure (Tongue and Groove)** — Minimum 1-1/2 in. thick 2 x 6, commercial graded lumber, continuous over two or more spans.
8. **Purlins – (Deck Supports)** – Spaced a max of 24 in. OC Any of the following types may be used:
 A. No. 22 MSG min thick coated steel. (33 ksi min yield strength.)
 B. Graded dimension lumber, No. 2 or better
- 8A. **Plywood Fasteners – (Not Shown)** – Fasteners used to attach the plywood deck (Item 7) to the supports (Item 8) to be as follows:
 A. For plywood-to-wood supports, No. 8-18 by 1-7/8 in. long bugle-head steel screws with a No. 2 Phillips drive, a "Hi-Low" thread pattern and an "S-Point".
 B. As an alternate to Item A, No. 8d common deformed shank nails may be used.
 C. For plywood-to-steel supports for a steel thickness less than No. 20 MSG, No. 7-19 by 1-1/4 in. long bugle-head steel screws with a No. 2 Phillips head drive, a "Hi-Low" thread pattern and an "S-Point". For a steel thickness greater than No. 20 MSG to No. 16 MSG, No. 6-20 by 1-1/4 in. long bugle-head steel screws with a No. 2 Phillips drive and an S12 (Tek/3) point.
 Spacing – For all fastener types to be 6 in. OC at the plywood edges and 12 in. OC in the interior.
- 8B. **Substructure (tongue and groove) Fasteners – (Not Shown)**
 A. Fasteners used to attach Tongue and Groove substructure (Item 7A) to wood trusses or joists (Item 8) to be 3 in. long 8d common deformed shank nails. Two nails per board at each support.
 B. For lumber-to-steel supports for a steel thickness less than No. 20 MSG, No. 7-19 by 1-1/4 in. long bugle-head steel screws with a No. 2 Phillips head drive, a "Hi-Low" thread pattern and an "S-Point". For a steel thickness greater than No. 20 MSG to No. 16 MSG, No. 6-20 by 1-1/4 in. long bugle-head steel screws with a No. 2 Phillips drive and an S12 (Tek/3) point.

Refer to General Information, Roof Deck Construction, (Roofing Materials and Systems Directory) for items not evaluated.

*Indicates such products shall bear the UL or cUL Certification Mark for jurisdictions employing the UL or cUL Certification (such as Canada), respectively.

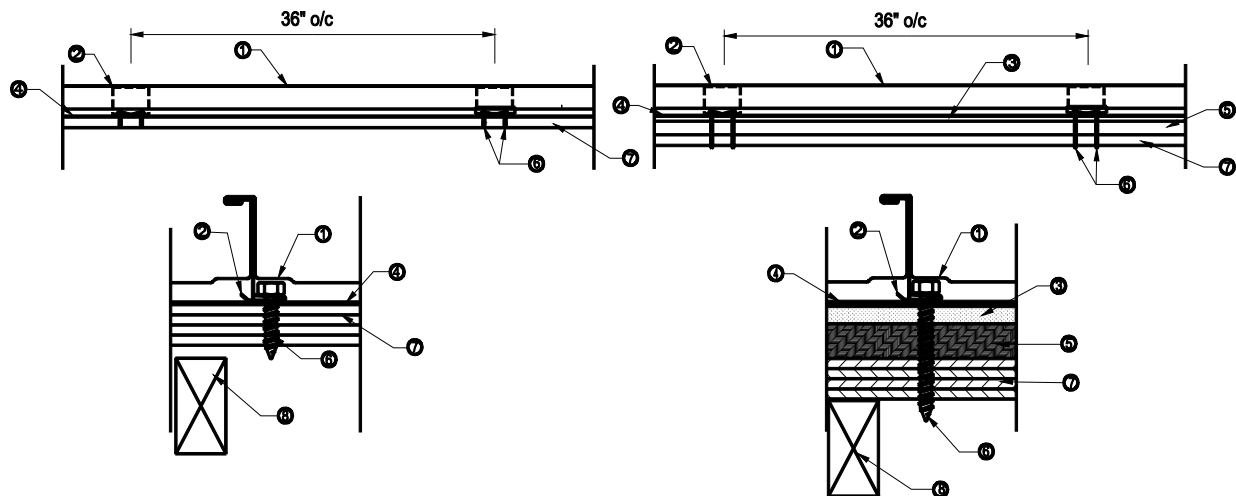

MANUFACTURING LOCATIONS

ADELANTO, CA	ASHBURN, GA	BOSSIER CITY, LA	CLINTON, IL	DIAMOND, MO	HOUSTON, TX	LEWISPORT, KY
MARSHALL, MI	MAUSTON, WI	MERKEL, TX	PEACHTREE CITY, GA	SUNNYVALE, TX	WINCHESTER, VA	