

Technical Bulletin

Issue Date: September 9, 2002

Revised: August 7, 2024

No. 03-144-02

UL Construction #310 Medallion I/SL Low Panel

UL580 Class 90 Wind Uplift

1. **Metal Roof Deck Panels*** - No. 24 MSG min. coated steel. Max panel width 16-1/2 in. End laps to occur adjacent to supports with panels overlapped 4 in. min.
McElroy Metal Mill, Inc. "Medallion" or "ABC SL Low Panel"
- 1A. **Metal Roof Deck Panels*** — (Not Shown) - Coated steel panels may be physically curved at a radius of 20 ft or greater or mechanically curved between 4 ft and 2 nominal 19 ft.
McElroy Metal Mill, Inc. "Medallion"
- 1A1. **Metal Roof Deck Panels*** — (Not Shown)- .032 aluminum panels. Max panel width 16 ½ in. and rib height ¾ in. End laps to occur adjacent to steel supports with panels overlapped 4 in. min.
McElroy Metal Mill, Inc. "Medallion"
- 1B. **Metal Roof Deck Panels* (Battens)** – Battens covering panel ribs and clips to be 3/8 in. wide and 7/8 in. high, formed from same type and thickness material as that used to fabricate metal panels (Item 1, 1A and 1A1).
McElroy Metal Mill, Inc. "Medallion I Batten"
2. **Roof Deck Fasteners*(Panel Clips)**– One piece, ¾ in. high, 1-1/2 in. wide by 2 in. long. Min 24 gauge, coated steel clip. When coated steel metal roof deck panels used (Item 1 and 1A) clips are spaced 24 in. O.C.; when aluminum metal roof deck panels used (Item 1A1) clips are spaced 12 in. O.C. Guide holes in bottom of clip.
McElroy Metal Mill, Inc. "Medallion I"
3. **Fasteners – (Screws)** – Screws used to attach plywood or OSB substructure (Item 4) to metal deck to be No. 14 diameter with Phillips or square drive head. Fastener length to be min of 1/2 in. longer than total thickness of the plywood or OSB , insulation and metal deck. Spacing to be 6 in. OC at plywood or OSB ends and 12 in. OC at 2 ft 0 in. pattern down length of plywood. (Total of 33 fasteners per 4 by 8 ft plywood or OSB sheet). Screws used to attach panel clips to plywood or OSB to be No. 10 by 1 in. long pancake head wood screw with No. 2 Phillips head size. One screw per clip. (Alternate — When bearing plates or oriented strand board (OSB) replace plywood). Screws used to attach panel clips through bearing plate into metal deck to be No. 14 type with Phillips head. Fastener length to be min of ½ in. longer than the total thickness of the insulation and metal deck. One per clip. An optional No. 10 by 1 in. self-drilling fastener may be used to attach clip to the bearing plate when installer chooses to install rigid board insulation and use bearing plate to hold it in place until clips and panels are installed.
4. **Plywood or OSB** – (Optional) – (Not shown)Min APA Rated plywood, exposure sheathing span C-D 40/20, nominal ½ in. thick or oriented strand board (OSB), nominal 7/16 in. thick, 4 x 8 ft. Sheets to be installed on top of Rigid Insulation (Item 5) in lieu of bearing plates (Item 4A). To be used with Rigid Insulation (Item 5), max thickness 10 in.
- 4A. **Substructure – (Bearing Plates)** (Optional) (Not Shown) – To be used in lieu of plywood or OSB (Item 4) with rigid insulation (Item 5) up to a maximum thickness of 10 in. Bearing plates to be 16 MSG min coated steel. Located under each clip (Item 2) for support.
5. **Rigid Insulation – (Optional)** – Foamed plastic, max thickness 10 in. when plywood or OSB (Item 4) or bearing plates (Item 4A) are used. Density to be a min. of 2 PCF. or see products Classified under TJBX.
- 5A. **Gypsum Board** – (Optional, Not Shown) – Any 5/8 in. thick gypsum wallboard supplied in sheets 2x4 to 4x12 ft. Applied perpendicular to steel deck direction with adhesive. End joints to occur over crests of steel roof deck and be staggered 2 ft. in adjacent rows. The total cumulative thickness of the rigid board (Item 5) and gypsum board may not exceed total thicknesses shown under Item 5.
- 5B. **Waterproof Membrane** – (Optional) (Not Shown) – Used to protect plywood or OSB (Item 4). Installed under panels (Item 1).
- 5C. **Vapor Barrier** – (Optional) (Not Shown) – Installed on top of metal deck (Item 6) or on top of gypsum wallboard (Item 5A) if used. Minimum 6 mil plastic sheet.
6. **Metal Deck** – 22 MSG min thickness coated steel. Min depth 1-1/2 in. with deck to be welded to purlin in every other low flute, except for end laps which are welded in every low flute.
- 6A. **Metal Deck** – (Liner Panel) – Alternate to Item 6 — No. 18 MSG min thickness coated steel (33,000 psi min yield strength). Min depth 1-1/2 in., max pitch 6 in. Installed and attached to supports (Item 7A) with fastener spacing and type per deck manufacturer's instructions for uplift loading.
7. **Purlin** – Min No. 14 MSG steel (55,000 psi min yield strength).
- 7A. **Supports** – (Purlins) — Purlins used for liner panel support (Item 6) to be cold formed steel sections or structural steel components (hot rolled beams, channels, open web joists, etc.) may be used. Support spacing, min gauge and yield strength to depend on design conditions for uplift loading.

Refer to General Information, Roof Deck Constructions, (Roofing Materials and Systems Directory) for items not evaluated.

*Indicates such products shall bear the UL or cUL Certification Mark for jurisdictions employing the UL or cUL Certification (such as Canada), respectively.

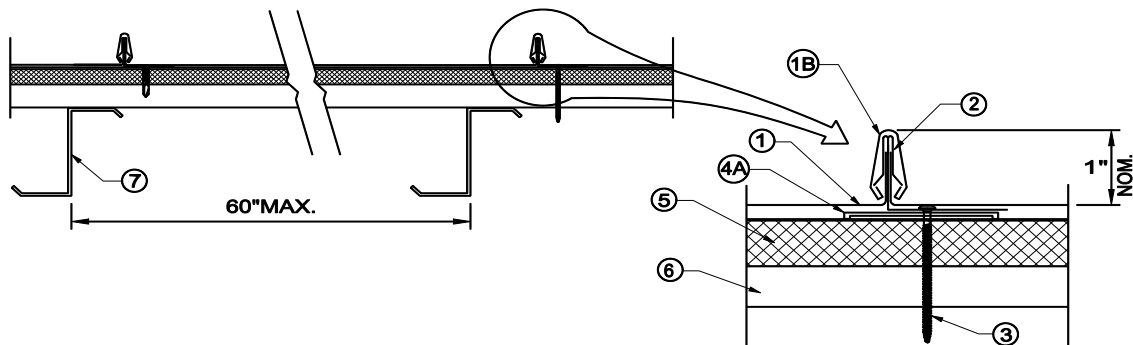

MANUFACTURING LOCATIONS

ADELANTO, CA	ASHBURN, GA	BOSSIER CITY, LA	CLINTON, IL	DIAMOND, MO	HOUSTON, TX	LEWISPORT, KY
MARSHALL, MI	MAUSTON, WI	MERKEL, TX	PEACHTREE CITY, GA	SUNNYVALE, TX	WINCHESTER, VA	